



GWYNEDD DESIGN GUIDE

INDEX

Part 1Design Guide

Introduction.....	1
Choosing and Planning	2
Site Development.....	3
Sustainable Development	4
Building Design	5
Historic Environment	6
Development in Town.....	7
Shopfronts	8
Commercial Development	9
Building in the Countryside	10
Repairs.....	11
Alterations and Extensions.....	12
Crime Prevention	13
Public Realm	14
Affordable Housing.....	15
Further Information	Appendix 1
Contacts.....	Appendix 2

Part 2.....Landscape Guide

Introduction

Landscape Character Areas (LCA)

- Area Wide Guidance
- Transport Corridors
 - Agricultural Landscape
 - Further Information (Appendix A)

INTRODUCTION TO THE DESIGN GUIDE

Gwynedd is a county full of contrasts, from the University City of Bangor to the scattered settlements of the Lleyne peninsula, encompassing mountains and coastline, farmland and forestry. Linking all this together, however, is the particular character of the region, formed by its geology and climate, and inherent in the vernacular architecture of the stone and slate cottages tucked into the landscape for protection from the weather.

This uniqueness of character, developed over hundreds of years, is now being systematically destroyed by progressive changes to the very elements that define the quality and individuality of the region. These changes, often a response to new concepts, alien design styles and imported materials, may be carried out as a personal statement of individuality, in a misguided attempt to create a 'historic' identity, or in the spirit of improvement and modernisation – plastic windows, concrete tile roofing, pebbledash and lawsonii hedges, for example. In the same way that Gwynedd seeks to protect its language and cultural heritage, the integrity of its environment must be safeguarded from this type of unsympathetic development and alteration, and the imposition of styles that have no relevance to the locality.

The establishment of good design practices is seen by the Council as having a significant benefit throughout the county, not only by improving the quality of its environment and enhancing its image and reputation, but also because good design is central to the quality of life for the people of Gwynedd. Guidance is therefore required to assist and advise those who are involved in the planning and development process, including:

- Property owners, to help them develop proposals that will positively contribute to the local distinctiveness and character of Gwynedd
- Applicants and agents, during the preparation and submission of an application, and the design statement to accompany it
- Development Control Officers within the Council, when dealing with applications.

Importantly the guidance also provides advice in relation to minor “permitted development” proposals. For these schemes, planning consent is not necessary, although this does not preclude other statutory requirements such as Building Regulations Approval, Listed Building Consents or other specific controls. However, they often involve seemingly minor details, such as the replacement of doors and windows, which can have a disproportionate effect upon the quality and character of buildings, particularly where they form part of a group or terrace. Proper consideration of the design of these features is as important as dealing with larger scale development schemes.

This Design Guide will complement other guidance prepared by the Council in relation to planning policies, landscape, highways, and wider environmental issues. Together, they will all contribute to raising the quality of the Gwynedd environment.

Until relatively recently design was not given the attention it deserved in National Planning Guidance.

Design issues were however given greater prominence in 2002 by the publication of Planning Policy Wales (March 2002) which states:-

“Good design can protect the environment and enhance its quality, help to attract businesses and investment, promote social inclusion and improve the quality of life. Good design should be the aim of all those involved in the development process and should be encouraged everywhere”.

In addition to the above the Welsh Assembly Government has issued a number of Technical Advice Notes, and Technical Advice Note 12 deals specifically with Design.

This Advice Note explains that design is not just the end product but is moreover a process. It states:-

“Design should be considered in its broadest sense as a collaborative, creative, problem solving process – embracing architecture, landscape, infrastructure and urban design that determines the quality of our environment and that can provide the basis for its sustainable future”.

The success of good design is therefore dependent on the involvement of those connected in this process as early as possible so as to develop a vision and agree design principles.

The purpose of this Design Guide is not however to prescribe the Design process but is intended moreover as a part of the “toolbox” in the design process.

CHOICE OF SITE

Before deciding on the site, consider:

Use of site and density

- Will the proposed use of the site be in line with the Local Authority's planning policies?
- Can the required buildings, roads and parking be accommodated on site without over-development?
- Does the site offer sufficient amenity space around buildings to prevent problems of overlooking, shading and noise, and to ensure pleasant surroundings?

Access and transport routes

- Are road and other access links suitable for the type of vehicles and volume of traffic that will be generated by the development?
- Are there adequate public transport links close by to enable non-car users to access the site and to minimise car use?
- Can existing pedestrian and cyclist routes be retained and enhanced?

Location

- Will the new development be compatible with its neighbours? Minimise the dangers from additional traffic, generation of noise and nuisance, pollution, and any increased security risk.
- Will it compromise the privacy of adjacent properties? Consider the relationship between fronts and backs of buildings both on, and adjoining, the site
- Will the development overload local services such as public transport, shops, schools, etc?
- Is the site suitable for a mixed use development? This can bring benefits of diversification of the economy, and ensure the area is fully utilised at all times.

Wildlife and landscaping

- Will the development threaten any special wildlife habitats?
- Can existing wildlife corridors be retained and enhanced?
- How can planting, mature trees, and hedgerows be retained? These allow the site to establish quickly and provide continuity.
- Can suitable indigenous species, adapted to the local environment, be used to reinforce planting?

SITE FEATURES

A detailed site appraisal will identify:

Land form and topography

- Topographical features of the site, such as gradients, ponds and watercourses, and how they may be exploited
- Whether it forms a flood plain
- Its geology – harmonise with natural materials and colours, utilise minerals or aggregates
- Location and species of existing planting, including individual or groups of trees, hedgerows and wildlife corridors
- Important views into and across the site, which should be preserved and enhanced
- Prominent high spots, which may be suitable for siting important or landmark buildings

Climate and microclimate

- Effects of climate – seasonal differences, prevailing wind, sun path and angle
- Modification of climate – shading and shelter by adjacent buildings and mature planting, degree and orientation of slopes
- Negative climatic effects – frost pockets, wind funnels, flood risk
- Reduction of energy costs in use by positioning the building to benefit from solar gain and make use of natural shelter

Manmade features

- Existing buildings offering potential for reuse or recycling
- Overhead and underground services, mining or quarrying
- Ground contamination from previous uses
- Roads, paths and site accesses; boundary walls and fences, etc.

Services

- Are adequate power supplies and services available on or near the site?
- Can natural water reserves be used for water supply or energy generation?
- Could alternative energy sources be utilised – ground rods, methane gas, solar or wind power?
- Or could a resource for other sites be provided, for example a district heating scheme?

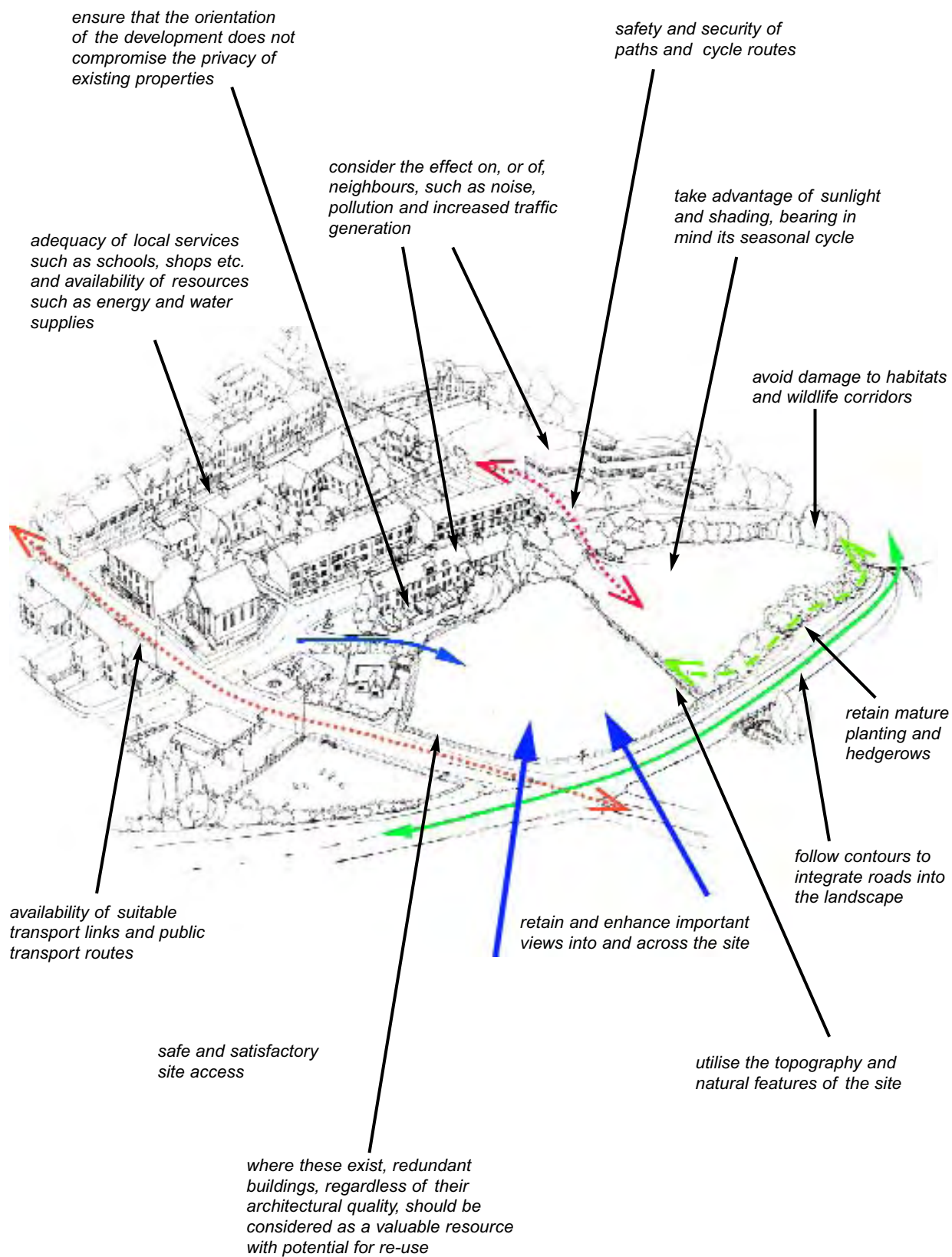

SITE CONTEXT

Assess the characteristics that define the surroundings' sense of place:

Setting

- The character of an area is defined by the grouping of the buildings and the nature of the spaces between them
- New development should respect and reinforce the local identity, by following similar design principles
- Where a contrast in scale or style is considered to be appropriate, for example, to create a new centre or focus, its design must be particularly sensitive
- Formal spaces have regular street patterns, similar sized plots and straight building lines
- Varied plot sizes and open spaces, with curved or winding roads following contours, creates informality
- Enclosure is created where building frontages and boundary walls are tight to the back of roads or pavements
- Open spaces need to be well defined by good quality landscaping if they are to feel secure and inviting

Scale

- Both spaces and buildings need to be designed to a scale which is appropriate to their location and function
- Large spaces and a grand scale should be reserved for public or corporate developments
- Residential areas need to be small-scale to create individuality and a sense of personal ownership

Views

- Views across, into and out of the site are important to locate the development within its surroundings
- Contrasting linked spaces provide a changing scene as the viewer moves through them
- Gaps, giving interesting glimpses of focal points or other spaces, invite further investigation
- Changes in level effectively contain or give depth to views
- New development, in conjunction with planting, can be utilised to form effective screening of existing unsightly features

SITE LAYOUT

Successful development relies on a number of considerations:

Hierarchy of development

- Assess the relative importance of every building within the overall development, and locate them appropriately
- Open spaces should be designed with as much attention to detail as the buildings themselves
- All elements should be integrated into a unified scheme, even if they are being designed and built individually
- Roads and parking areas should not dictate the layout, and should never be allowed to dominate it

Movement around the site

- Roads and paths should follow topographical features, not conflict with them, to ensure that they integrate into the landscape
- If possible, existing routes and access points should be retained for continuity of land use patterns
- A hierarchy of routes for different users improves safety, and enables vehicle numbers and speeds to be controlled
- Speed restraint should be an integral part of road design
- Routes should be clear and direct, creating connections, but avoiding too many through routes which are difficult to control
- Pedestrian and cycle routes particularly, should be located where they have a defined ownership and will be well-used, to encourage both a sense of security and a reduction in car use

Parking

- Guidance is available from the Planning Authority on the density of parking provision required for any development
- Parking areas which clearly belong to a building and which can be overlooked by its occupants are more easily secured against criminal activity
- Breaking up large car parks into manageable areas reduces the impact and improves security
- Casual parking provision for residential developments should be well distributed to serve the needs of all properties

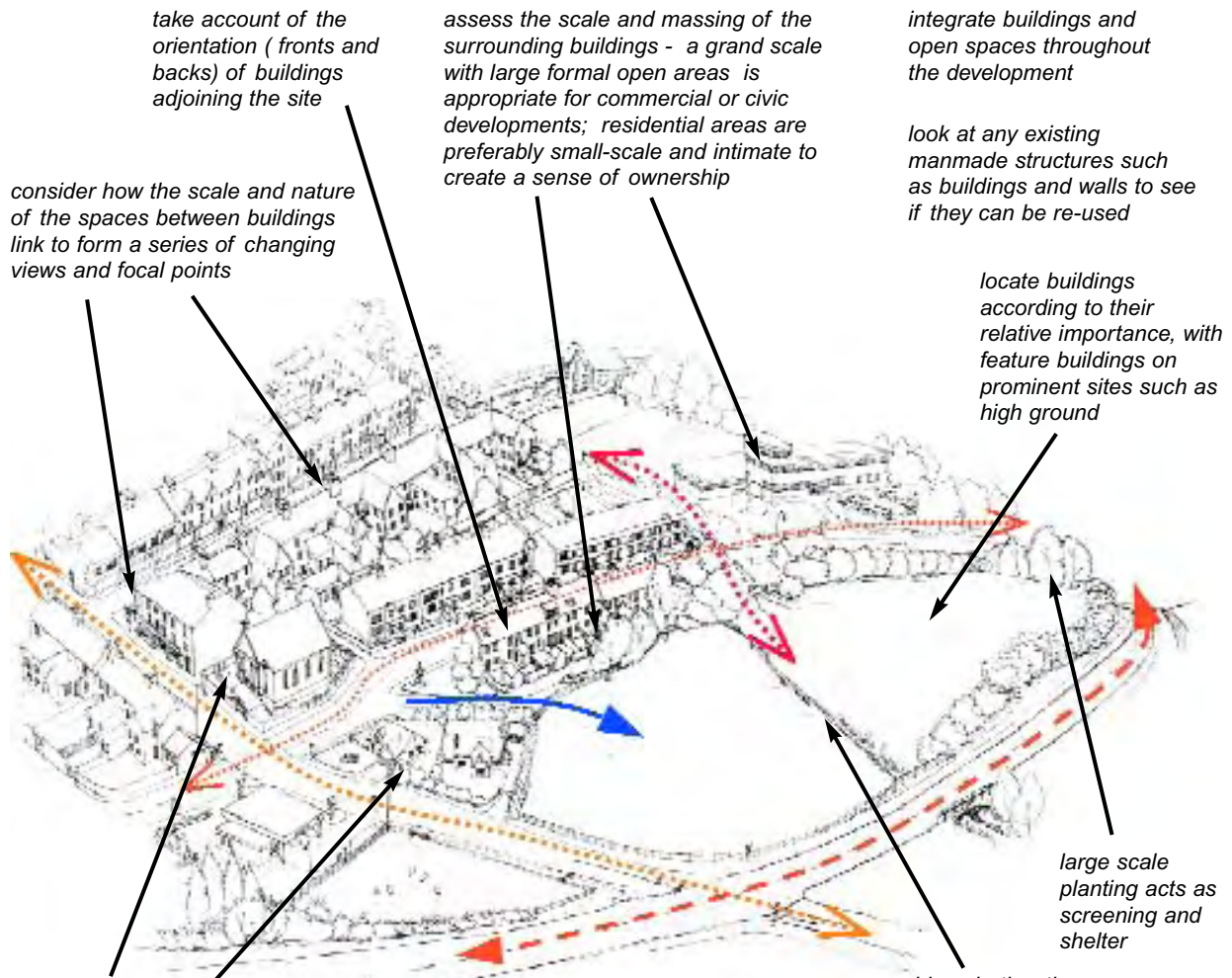

take account of the orientation (fronts and backs) of buildings adjoining the site

assess the scale and massing of the surrounding buildings - a grand scale with large formal open areas is appropriate for commercial or civic developments; residential areas are preferably small-scale and intimate to create a sense of ownership

integrate buildings and open spaces throughout the development

consider how the scale and nature of the spaces between buildings link to form a series of changing views and focal points

look at any existing manmade structures such as buildings and walls to see if they can be re-used

locate buildings according to their relative importance, with feature buildings on prominent sites such as high ground

large scale planting acts as screening and shelter

decide whether the layout of the surrounding area is formal or informal, urban or rural, and which is appropriate for the new development

consider whether there are any landmark buildings or important landscape features which could provide a focal point

utilise a hierarchy of routes to control the speed and volume of traffic generated by the development, with priority being given to vulnerable users

retain existing site access points and routes through the site where appropriate: all routes should be designed to connect logically the places where people want to go

vehicle movement should not dictate the layout nor dominate – routes should always reinforce the character of the site or area

create appropriate cross-site connections by means of clear and direct routes – this ensures that they are well-used, and improves safety and security



In many towns and villages, streets and buildings follow the contours, creating a settlement in harmony with its surroundings



Tall buildings and narrow streets create enclosed, urban spaces, heightening the apparent scale of the buildings



Open landscape-dominated spaces have a rural feel that reduces the impact and apparent scale of surrounding buildings



Informal layouts with winding roads suggest a series of linked spaces and changing views, inviting further exploration

LOCAL IDENTITY

In order to integrate new buildings into their surroundings, and to retain the local identity, designers need to:

- Ensure the proposals conform with local planning policies
- Assess the local character by careful appraisal of adjacent sites and buildings
- Understand local features, details, materials and traditional construction methods, and use them only in the correct context
- Design specifically for the site – standard or poor design solutions ‘customised’ by the addition of local features will not provide satisfactory results
- Have regard for the impact of the new development on both immediate neighbours, and also the wider community
- Take a particularly sensitive approach in Conservation Areas or other intact historic locations

Techniques to ensure new buildings maintain the sense of place include:

- Building within existing street patterns, if these exist, and keeping to existing building lines and plot boundaries
- Designing new layouts to fit in with adjoining spaces – in urban settings, for example, buildings are set close to the back of the pavement, and have boundary walls or dense hedges, whereas open plan frontages and low planting can be used to create the feel of a rural neighbourhood
- Reproducing features that are consistent, such as plot width, roof span, eaves height
- Retaining a degree of uniformity, by using a ‘house style’ to achieve variety and individuality
- Avoiding superfluous decoration or imitation historic styling – keep to classic forms and proportions, and simple, uncluttered detailing
- Ensuring planting and landscaping uses indigenous species, and those that are suited to the location – bear in mind mature height and spread, leaf fall, future maintenance

Achieving the correct balance between these requirements is essential for good design, and will enhance the value of the building or development

SUSTAINABILITY

A flexible and sustainable solution requires consideration at all stages of the design process, and can be achieved by

- Considering all alternatives before making a decision to develop
- Responding sensitively and effectively to the constraints and opportunities of the site
- Designing to maximise the use of renewable resources – orientating the building to make use of sun light and heat, or collecting and re-using rainwater, for example
- Minimising the wastage of water by incorporating sustainable water management techniques
- Specifying ecologically sound materials, including timber from renewable sources, salvaged hardcore, and natural materials which are themselves recyclable
- Using energy efficient construction techniques and materials with low-energy methods of production
- Life-long energy efficiency by means of high levels of thermal insulation, reduction of heat loss through draughts
- Specification of long-lasting and low-maintenance products, coupled with quality detailing, good workmanship, and use of construction methods and techniques consistent with them
- Incorporating opportunities to reduce, re-use or recycle waste, both during and after the construction process
- Improving the energy efficiency of existing buildings instead of replacing them
- Bringing redundant or under-used buildings back into full use, including upper floors above shops and commercial premises
- Re-using totally derelict buildings as landscape features or boundary walls, or salvaging their materials
- Designing for safety and security, by creating a sense of ownership of, and natural surveillance over, open and public spaces, control of access to private spaces, and designing out features which encourage or facilitate crime
- Ensuring buildings are fully adaptable for future changes of circumstance, disability, etc.
- Making sure a full range of services are available locally, to preclude the need to travel out of the area or relocate

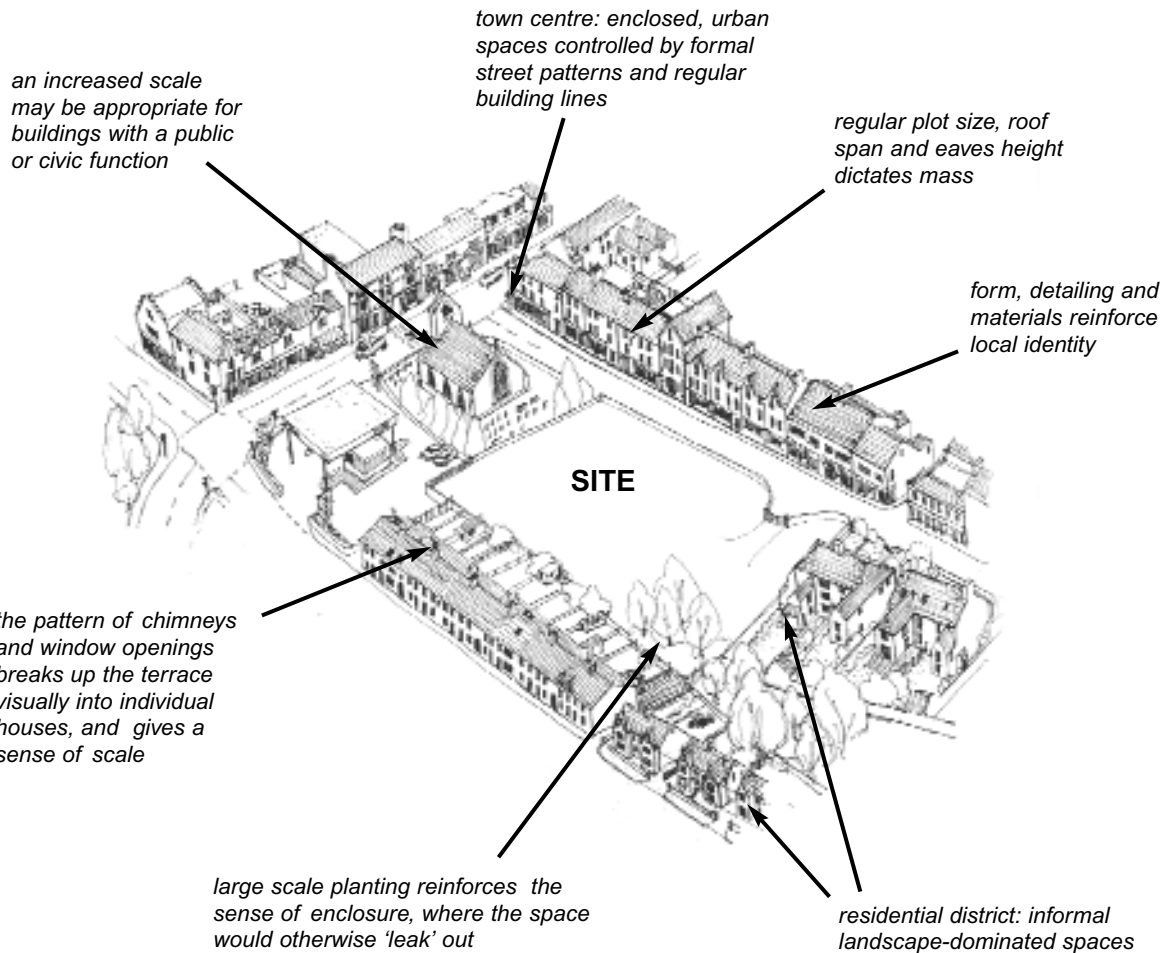

A lack of respect for local identity, and the use of a wide range of styles, materials, forms and detailing, does not create a cohesive neighbourhood with a distinct sense of place

The new build (left) has been designed to reflect local character, mass and scale; the false dormers serve no purpose but, in the absence of chimneys, they break up the roofline and reinforce the regular pattern of the terrace



Redundant good quality buildings should be adapted for re-use, keeping their original characteristics intact; this not only demonstrates sustainable development, but also ensures retention of local identity



Variety in mass, form and scale



Repetition of elements in this façade demonstrates formality



Deeply-set windows and feature gables express 3-dimensionality



Decoration may be added to essential details

APPEARANCE

The following factors affect the overall appearance of a building

Mass, Form and Scale

- The shape, size and presence of a building within the landscape or street scene should respect the spatial quality of its surroundings
- Assembling a large building from a number of smaller units of appropriate form reduces its apparent mass and scale

Formality / Informality

- The mass of the building will be sub-divided by elements, for example window openings, which may be arranged regularly or informally, horizontally or vertically
- It is more pleasing to the eye to have a symmetrical or balanced arrangements of elements rather than a discordant one

Depth and Modelling

- Depth and modelling will give an otherwise flat, featureless façade a three-dimensional quality

Detail

- Whilst detailing may be adapted as a means of decoration, it is primarily practical – for example structural or weather protection
- Applied decoration is rarely successful if it tries to impose a style inappropriate to the design, such as false half timbering on a modern estate house

Materials

- Use materials honestly - heavy stonework supported on light-weight infill, for example, can be visually disturbing
- Use of local materials helps a building to integrate with its surroundings and provides continuity within the streetscape
- Natural materials have textures and subtle colour variations not apparent in manufactured ones

Function

- The function of a building should be expressed in its design



A traditional street pattern has regular plot widths, roof spans and eaves heights, which control the mass, form and scale of the buildings, whether they are varied in design, or identical terraced properties



Terraces are usually quite unified: this one has a much more informal feel with its irregular roofline and modernised opening sizes and proportions

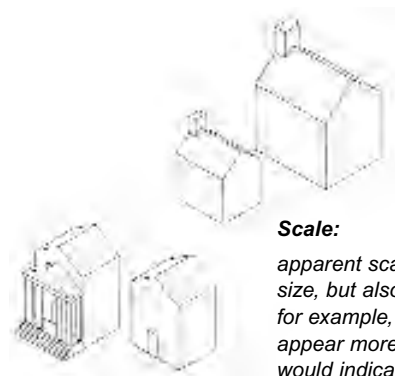

Mass and form:

the layout, height and construction of a building, and whether it is composed of a single large unit or several inter-connected smaller units, will determine its mass and form

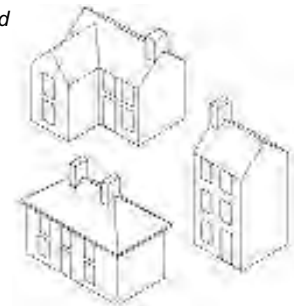

Scale:

apparent scale depends not only on actual size, but also on design – a civic building, for example, may have features to make it appear more imposing than its size alone would indicate

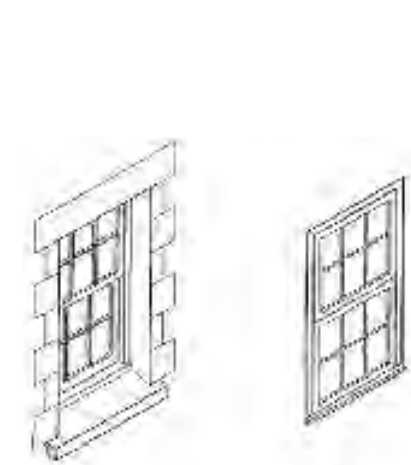

Formality | Informality:

the repetition of a terrace of similar units is formal; a classically designed building also demonstrates formality

Depth and Modelling:

traditionally, windows are inset into the wall for weather protection, which gives depth to the façade(left); windows set on the face of the wall give it a flat, shadowless appearance(right)



Even if locally sourced, inappropriate use of materials should be avoided – the slate hanging (left), whilst being a traditional method of construction, appears clumsy in small areas; the machine-cut random rubble stone (right) looks more like stone facing than quarried stone blocks

In the correct context and using suitable techniques, local materials help to create a sense of place by conveying the colour and feel of the surroundings

THESE GENERAL PRINCIPLES SHOULD ALSO APPLY TO THE DESIGN OF EXTENSIONS

PROTECTION OF HISTORIC ENVIRONMENT

Built Environment

In addition to normal planning controls, further constraints apply to particular areas or buildings whose special qualities, such as architectural or historic importance, distinct identity or local character, deserve protection

- **Conservation Areas**

Areas whose special character – of architectural or historic interest – should be preserved and enhanced

- **Listed Buildings**

A building or significant group of buildings with a special historic, architectural or cultural merit

- **Scheduled Ancient Monuments**

Historic remains such as castles, industrial sites, standing stones

Protection

- Any proposed development or alteration should be in line with local planning policies: the Council will be able to advise
- Conservation Areas are not historically static – new high quality development to replace or improve existing inappropriate or poor elements will be encouraged
- All development within or affecting views of or from a Conservation Area, including the conversion or re-use of neglected buildings, should contribute positively to the character of the area
- Conservation Area controls apply to trees, boundaries, signage and advertising, surfaces and street furniture; open spaces and street patterns are especially important
- Alterations to a Listed Building must not be detrimental to its character; internal features and fixtures, and the curtilage and setting, are also protected
- Retain original elements wherever possible; replacement and repairs should be carried out using the correct materials and techniques appropriate to the age and original construction of the building

Landscape

For advice on protection of landscapes and ecological features, refer to The Landscape Working for Gwynedd 2001

Advice and Consent

- When planning any work within a Conservation Area or to a Listed Building, consult the Council at an early stage for advice, and to ensure compliance with all necessary consents
- It is a criminal offence to carry out any works to a Listed Building which require consent, unless that consent has been obtained

Appropriate Work

- The style or design and materials would normally be to match the original building, although in certain circumstances a contrast may be appropriate, such as a glazed link between two buildings
- Repairs must be carried out on a like-for-like basis – replacement windows, for example, should be identical not only in style, but also in material
- Retain or replicate roof form and pitch, and use traditional materials, such as natural slates, clay ridge tiles and lead flashings
- Original rooflights and dormer windows are small in size, and relatively inconspicuous; pitched roofs are appropriate on dormers
- Chimneys should be retained even if they are redundant; avoid condensation by providing ventilation to unused flues
- Re-facing a building by cladding, pebbledash or cement render, or the removal of original render or stucco, alters its character
- Original sash and casement windows can, in most cases, be repaired successfully; draught-proofing cuts noise and heat loss
- Retain features such as door surrounds, panelled doors and glazed fanlights, which are part of the character of the building
- Rainwater goods would generally be cast iron; plastic gutters and pipes are not appropriate
- Refer also to the section on Repairs, page 11, and Local Authority Public Information Leaflets for further guidance

Grants

Financial assistance to carry out appropriate repairs may be available from various sources – the Council will be able to advise on eligibility

The following points are important when extending or altering Listed or historic buildings, and those within Conservation Areas, in order to preserve original detail and materials, and protect and enhance the local character

chimneys should be retained, including the original chimney pots, and any other features such as the stone water tabling which protects the junction of the roof and chimney

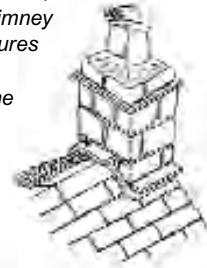

retain original cast iron rooflights, or renew with 'conservation' style rooflights, which are small and do not protrude above the roof finish



roofs are usually covered with either blue or purple Welsh slates, depending on the location within the county

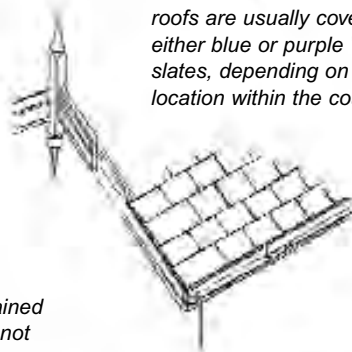

rainwater goods – downpipes and gutters – should be cast iron, typically painted gloss black



certain building styles are defined by bargeboards and finials – these should be retained where they exist, but should not be introduced inappropriately

eaves are generally open or with a small fascia board only

pebbledashing, especially using coloured or imported chippings, should be avoided – it obliterates local materials and character, giving the building a bland, mundane appearance lacking in any sense of belonging within its neighbourhood

do not render over stone or brickwork, or remove original render



windows and doors should be repaired or replaced like-for-like in both style and materials – upvc replacements rarely provide a good match for traditional windows, with their heavy frames, lack of fine detail, and flat appearance

lintels above and sills below windows, and all decorative features, should be retained

boundary walls, fences and gates, and landscaping affecting the setting of, within the curtilage of a Listed Building, and in Conservation Areas, are all protected in the same way as the buildings

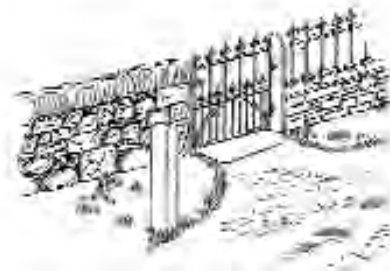

Conservation Areas have a special character that not only warrants additional protection against unsuitable or intrusive development, but also deserves positive enhancement



Listed Buildings may be important as part of the townscape character, as well as having an individual quality



They may be isolated, small or large, but in all cases any proposals for alteration have to preserve and enhance their distinctiveness



Although a Scheduled Ancient Monument is unlikely to be altered, any proposed development that affects its environs and setting is subject to rigorous scrutiny

INFILL SITES

When designing for small or infill sites, or remodeling existing buildings in town centre locations, take into account the following factors:

- A careful analysis of, and response to, the surrounding sense of enclosure, formality and scale is essential
- Mixed use, especially in town centres, encourages full use round the clock, and improves security; however, control of noise, light pollution etc. needs particular consideration
- A sound understanding of the principles of the design of neighbouring buildings, both architectural and historic, is required, to ensure the new building responds effectively
- Imitation of neighbouring architectural detailing out of context gives a false sense of historic value or scale, and rarely produces a quality building
- Where the streetscape has a very definite character or is historically intact, the design will need to be particularly sensitive, but should not necessarily try to copy its surroundings
- Good modern design may be more appropriate, especially for a landmark site or where it will create a focal point; it can enhance and complement the surrounding streetscape, create historic continuity, and ensure economic success for the area
- Corporate identity can be maintained, but should be low-key; standard shopfronts, house style signage and detailing, lighting, and corporate colour schemes, should all follow the basic rules of scale and proportion, and should be designed to be in keeping with the style of building
- The hours of use of a town centre can be increased by the provision of a range of services such as late-opening cafés; shops which are closed appear less intimidating if the shop windows are lit, or if light is spilling through internal open mesh security grilles, rather than having closed security shutters
- Consider whether redevelopment is necessary – making full use of upper floors above shops provides a sustainable alternative, and may be more economically viable

LARGER SITES

Where larger developments are planned, for example a new housing estate, the basic design guidelines still apply:

- Particular attention should be paid to the spatial context of the surroundings, so that a development within the confines of a town would normally be formal, with a fairly enclosed feel, to avoid the spread of suburbia; a more open, informal layout may be appropriate for the outskirts
- In some circumstances, a development which has a different purpose may have a distinctive approach from its neighbours – for example, a residential scheme adjacent to the town centre shopping district, or commercial development designed to be the catalyst for regeneration of a run-down area
- The design must, however, be especially sensitive, to ensure the character and sense of place of the locality is both retained and enhanced
- Clear, direct routes for pedestrians, and measures to reduce traffic generation, should be integral to the design of the site; the road layouts should be developed in conjunction with, not as the controlling factor to, the site layout
- Buildings should be designed specifically for the site; standard house types rarely adapt well to level changes, for example, and the best use of site can be made where houses can be orientated to make use of the topography, maximise solar gain, and respond to surrounding features
- Good modern design has a timeless quality, and can enhance and improve an area; avoid 'fashion statement' detailing and false historic styles which begin to look dated, or standard house types which have no local relevance
- The re-use or conversion of a good quality redundant building, or group of buildings, such as a former industrial complex, may be appropriate where a suitable new use can be found which is in line with Council policy, and provided the character of the building and surrounding area will not be compromised

Good modern developments respect, even if they contrast with, their neighbours, but in all cases they enhance and maintain the ambience of their surroundings



The use of innovative design and modern materials will be welcomed, so long as they complement and enhance their surroundings



A new building in a constrained infill site should follow the principles of mass, form and scale established by the surrounding buildings – where there is a larger plot, it may also be appropriate to visually sub-divide the building to replicate the plot widths in line with the adjoining properties



The regular pattern of a street is controlled by mass, form and scale; buildings that do not follow these principles give a disjointed feel to the street frontage



A landmark building creates a natural focal point on a prominent corner site



The opportunity for an exciting and high quality new building on this corner site has been missed in favour of a safe solution, which merely avoids conflict with its neighbours



By contrast, the building on this corner site makes a definite statement but at the same time sits well amongst its neighbours



Modern design will look out of place if it has no regard for the scale, form or materials of its neighbours



The style and form of modern buildings should relate to their surroundings – this urban style brings to mind a formal built-up area, not a suburban or semi-rural site



An unsympathetic form or new building cannot be given an 'historic character' by the addition of false, and irrelevant, detail

SHOPFRONTS

Traditionally, shopfronts comprised the following elements:

A Fascia and signage, with

B Cornice for weather protection, and

C Pilaster Headcase

Fascia, with painted lettering, may be angled to allow the sign to be read from street level; a blind box for a canvas awning may be located below the cornice. The size, height and ratio of the fascia determine the scale and proportion of the street frontage; illumination should be by concealed lighting

D Window, subdivided by

E Transome (horizontal) and

F Mullion (vertical)

Signs or stickers should not cover the glass – allow the contents to advertise themselves

G Pilaster, with

H Capital or Console at head, and

I Plinth at base

Gives vertical emphasis, and visual strength and support to upper floors; pilasters between adjoining shopfronts should be retained when interconnecting premises

J Stallriser

Forms a strong base to the window and provides protection at low level

Existing buildings

- Existing original shopfronts should be retained and repaired if possible
- Only where historic records are available showing the original should a missing or badly defaced shopfront be replicated
- In the absence of records a more modern, but sympathetic, design is preferable to a historically ambiguous reproduction

New buildings

- A contemporary shopfront should relate to the building itself and its neighbours in proportion, scale and style, but should not copy them
- Innovative buildings should not be given a false historic identity by means of a reproduction shopfront
- Adopting simple, classic lines and a restrained palette of materials will result in a design that fits well in its surroundings and does not date

GUIDELINES

The whole character of a town centre or village can be changed by the insertion of inappropriate shopfronts; points to bear in mind are:

- Keep to the scale and proportion of the original, which should relate to neighbouring shops
- Sufficient solid construction needs to be retained at each side of the opening, otherwise the frontage looks weak, with inadequate structural support for upper floors
- Where two or more units are combined, sub-divide the new shopfront to replicate the plot widths of the buildings above
- Traditionally, shopfronts were painted softwood timber; hardwood, aluminium or similar materials are best avoided in a historic town or village centre
- Maintain a 'stallriser' or solid portion of construction below the shop window – this is visually more satisfactory, provides a defence against ram-raiding, and allows the internal display floor to be raised nearer to eye level
- Recessed doors give shelter, increase the display window area, and provide a safe space for the swing of the door
- Large or internally-illuminated signs are not appropriate in a traditional town centre – simple painted signage within the fascia of the shopfront, with recessed lighting, can be very effective
- Corporate signage and logos are acceptable so long as they are kept within the height and width limits of the fascia
- Shiny plastic or 'dutch' style blinds are not suited to the locality; traditional roller blinds, which retract into a blind box forming part of the shopfront fascia, are almost unnoticeable when closed, and are efficient at shading the shop window when open
- Security screens and shutters which give a fortress-like appearance when closed can be intimidating to passers-by, limiting use of the town centre out of normal shopping hours; internal grilles allow light to spill out, and encourage window shopping, but still provide a deterrent to theft
- Shops, as all buildings, must be fully accessible to all, including the disabled and less-abled



Traditionally detailed shopfronts were designed to 'sell' the shop without the need for further embellishment such as oversized signage, fussy lighting, or corporate identity



Over-large signs can unbalance a similarly traditional shopfront – high street chains and franchises often promote corporate identity this way

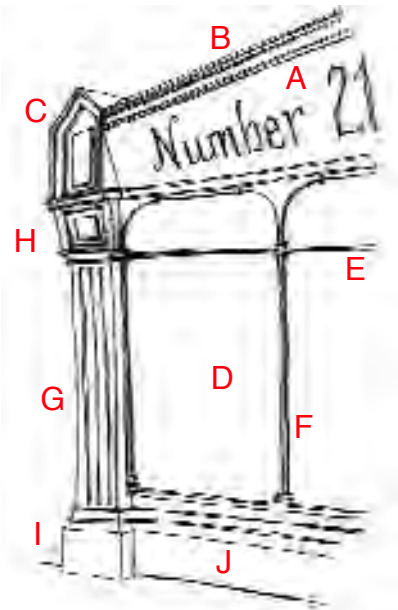

Traditional shopfronts vary in design, but all are assembled from the same elements – a successful modern shopfront should not copy, but should be sympathetic to the scale, proportion and general feel of the surrounding buildings



Canvas awnings shield the window contents from direct sunlight but can be retracted fully out of sight into the shopfront when not required



Dutch blinds are always visible even when folded up; they are much more obtrusive than traditional blinds, and do not have the right feel for an established town centre



Shopfronts extending over multiple units without intermediate support, or appearing to have insufficient structure to carry upper floors, give a feeling of instability, and relate poorly to the original plot widths



By contrast this new building, which completes an eighteenth century terrace, has shopfronts that replicate the plot widths, are traditional in feel, but are not pastiche; corporate identity is in evidence, but being low key, does not dominate



Good modern detailing along traditional lines respects but does not imitate; tidy forecourts and buildings with lively displays make for a welcoming and vibrant commercial district



Solid security shutters neither permit light to spill out nor provide the opportunity to look in to the window; too many shops with closed shutters can make the street feel like a no-go area, making it uncomfortable for people using the town as a meeting place out of normal business hours and discouraging natural interaction, thus reducing the chances of passive surveillance



Shutters located behind glazing do not compromise the shopfront; internally lit displays can be seen through open or pierced grilles, promoting out-of-hours window shopping

COMMERCIAL AND INDUSTRIAL SITES

A masterplan for the site must be in place for all commercial and industrial developments, such as out-of-town retail parks, industrial or trading estates and similar large scale developments. Even though individual buildings may have different designers, they should conform to the masterplan:

- Road, path and bridle / cycleway networks, other transport links, parking and delivery bays, need to be planned to a suitable hierarchy – priority should be given to pedestrians where they would be the major users, such as retail parks; vehicles may have priority on industrial estates
- Structure planting will define and screen the site, provide shelter from the weather, and restrict the transfer of noise and light pollution from the site
- Location of public spaces, open amenity spaces, and a site-wide landscaping scheme will need to be considered at the initial design stage, using existing features reinforced with appropriate indigenous planting
- Existing buildings, walls, hedges, fences and similar features suitable for re-use, and adequate measures for the protection of existing planting both during, and subsequent to, construction, will need to be identified
- Integration of underground services, overhead cables, lighting, etc. and provision for connection at each plot, is essential
- Proposals to conserve and create energy wherever possible, and to limit the use of scarce resources, by designing appropriately should be identified at an early stage
- An agreed framework for ensuring harmony in the design of individual buildings, relevant to the local character, must be provided to enable designers to create a unified scheme
- High quality innovative design can have economic benefits, and will be encouraged in appropriate locations

The Gwynedd Unitary Development Plan provides a framework for the development of such projects, and proposals should be discussed with the Council at an early stage

DESIGN CONSIDERATIONS

Development for commercial or industrial uses can have a disproportionate effect on the character of an area if it is not handled well; its design may be dependent upon the area in which it is proposed, but in all cases, it should relate to its surroundings

- Commercial or industrial developments in historic locations, or in areas with a distinct character, should reflect the scale, mass and form of the neighbouring buildings closely, without having a detrimental effect on them or their users
- Areas with a less well defined character may be more tolerant of modern design and corporate identity, although standard design solutions may need to be modified to complement the local character
- Whilst traditional materials and forms of construction are generally preferred, a more innovative approach may be acceptable for commercial and industrial developments, provided good design and high quality materials are evident
- Redundant buildings can often be converted successfully for commercial or industrial use; retain the character by avoiding changes which are detrimental to the building or the locality
- When converting floors above shops for residential or office use, avoid altering the character of the building by increasing the number or size of openings, installing large dormers or removing street accesses
- Ensure adequate provision for waste storage, or rear access to premises for refuse collection
- The use of corporate colours and signage will be dependent on the location; what may be acceptable alongside a main road or on an industrial estate would not be appropriate in a village setting
- Similarly with signage and lighting: avoid excessive advertising which can be counter-productive and, if adjacent to a highway, distracting
- Tourism and leisure developments especially should preserve and enhance local character, protect the landscape, and employ high quality design and materials



Industrial or commercial developments located out of town, or in areas of distinctive character, need to be especially sensitive to their surroundings



Modern design using materials that respond well to the locality in scale, form, proportion and colour, can produce a very sustainable and ecologically sound development solution



In less vulnerable environments, the use of non-traditional materials may be acceptable, coupled with a high quality specification, and consideration of appropriate colour and weathering characteristics



Local sense of place is lost if buildings lack any sympathy with the scale, form, materials or style of their neighbours



The widespread use of corporate 'house styles', distinctive colours and signage does not reinforce local character, especially in historic towns and villages, and should be tempered to suit the locality



In areas with a less clearly defined character, or where the surroundings are modern or urban, there is more scope for individuality and innovation, within a palette of materials and details



Fussy detailing, a profusion of signs, lights and services, and excessive advertising detract from both the building and the streetscape



Premises with solid external security shutters, and refuse piled in the street waiting collection, make a town feel uncomfortable and insecure out-of-hours



The conversion of small and large scale industrial units can be worthwhile on both sustainable and economical grounds, if suitable uses can be found

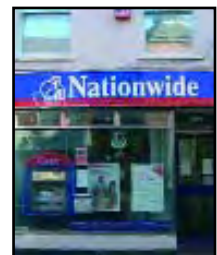

Town centres especially can be damaged by the actions of owners of commercial premises, such as allowing upper floors to become disused and dilapidated, out of character alterations, the insistence on corporate or distinctive colour and signage, displaying goods outside inappropriately; a tidy, well-cared for environment will be attractive to both visitors and locals, will feel more secure, and can be beneficial to the area, both economically and environmentally

NEW BUILDINGS

Siting

- Most settlements have a very specific character, which must be protected and enhanced by the development
- Analyse the relationship between surrounding buildings and spaces – regularity or informality in their arrangement, a feeling of openness or enclosure – and design accordingly
- Use the topography of the site to best advantage for shelter, screening, orientation and layout
- Road layouts should be designed for essential access only, giving priority to pedestrians, and providing natural means of traffic calming and speed reduction

Design considerations

- Design with sensitivity to the characteristics of the surrounding buildings
- Each building should be site specific – standard designs are rarely capable of responding to the constraints of a particular site
- Rural character is weakened by standard design solutions, which often feel too suburban, and the imposition of corporate identity
- Scale, design and materials need to respect the rural feel; urban, large-scale developments which would overwhelm the existing village should be avoided
- An integrated approach is required to ensure that the buildings and site features – landscaping, road layouts, boundary treatment and surface finishes – are in harmony
- Planting and soft landscaping, which should be indigenous species, will help to mellow newly completed developments more quickly, providing continuity within the settlement
- Hard landscaping, including paving, walls, fences, and street lighting, are important visually, and should retain the feel of the countryside, using appropriate materials and styles
- Design for flexibility and long life
 - energy efficiency
 - conservation of resources
 - adaptability to future change
 - use of natural materials
 - appropriate detailing
 - quality of workmanship
- Σ • security and safety

CONVERSIONS

The conversion of redundant buildings, especially where this provides the opportunity for farm diversification, or upgrading of poor quality or semi-derelict buildings, is a valuable reuse of existing resources

- Local planning policies will confirm which buildings can be converted, and to what alternative uses
- The building will need to be of reasonable quality and in a repairable condition
- The existing form of the building should be capable of fulfilling its new purpose satisfactorily without requiring major alteration or redesign
- It would preferably be located close to, or within an existing group of buildings, such as a disused barn on a farm complex
- The site would include a sufficient area of land to ensure amenity space and privacy, without detracting from adjoining buildings
- There is suitable access for the proposed usage

Design for conversion

The proposals for conversion of the building and site should conform to the general principles of design

- The proposed new use of the building should not conflict with its original character or that of any neighbouring buildings
- The form of the original building should be retained – existing attached sheds may be used to provide extra accommodation, but avoid adding extensions or outbuildings such as detached garages
- Eaves and ridge lines should not be altered; dormers and chimneys are not suitable on buildings whose former use was agricultural or industrial, but rooflights may be acceptable
- Retain original openings without altering their proportions or enlarging them; new ones, if they are essential, should be similar
- Use materials and detailing appropriate to the building type, or sympathetic to the existing, for example simple boarded doors on a barn conversion
- Landscaping, surface treatment and boundary materials should be appropriate



A dispersed settlement in the countryside typical of Gwynedd demonstrates the relationship of topography and buildings, which lie within, and are dominated by, the landscape



The layout of established villages also relates to the landform, with built elements creating enclosed, but still informal, spaces



A good example of a development in the countryside which uses the landscape, supplemented by shelter planting, to act as a barrier against visual, noise and nuisance pollution; to modify the climate and aid the energy efficiency of the buildings; to contain and control traffic, and to integrate the built and natural environments



With an integrated approach to site and building design, and following general and local design principles, even modern buildings using new materials can quickly blend in into the landscape



Although well sited, and using mature planting to integrate and shelter it, this property nevertheless lacks local character in its detailing



The same principles should be applied, especially with regard to siting, to all development in the countryside, whether building or not. This caravan park is located very prominently within the landscape: well-placed shelter planting would reduce the visual impact as viewed from a distance, improve on-site privacy, and may even provide the opportunity for greater density



This small housing development is entirely appropriate to its village setting, making good use as it does of the former plots and boundaries

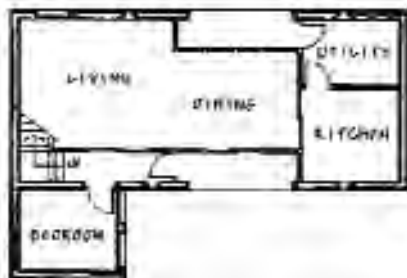

Adapting redundant buildings requires particular care, so that the original character is retained, without substantially changing the form or affecting the setting or surroundings of the building – make use of attached outbuildings instead of adding extensions; avoid adding features which are not characteristic, such as chimneys or dormers to barn conversions; design imaginatively to make use of the original barn door openings to create pleasant, well-lit spaces, for example, without destroying the integrity of the original building

FABRIC REPAIRS

Understanding the technical and practical reasons for using materials and detailing enables informed choices to be made on the methods of repairing the fabric of buildings:

Chimneys

- Traditionally, chimneys were large to accommodate many flues, and to absorb and re-radiate heat, with brick or stone banding or drips to strengthen the top and throw off rainwater
- Because of their mass they need to be located at visually strong positions, such as at the junction of the gable and ridge
- Chimneys define individual houses by breaking up roof lines, and their height and detailing gives scale and balance to roofscapes

Roofs

- Double pitch roofs with a natural slate finish, at between 30–40°, protect against severe weather and blend into the landscape
- Clipped verges and eaves with small overhangs are both robust and economical
- Stone-capped parapets give a feeling of strength to gables
- Natural slates, unlike concrete tiles, have a smooth or riven surface and subtle colour variations, producing a distinctive texture and finish to the roof
- Artificial slates which emulate this effect are available; ensure they do not change colour or deteriorate rapidly with age
- Clay plain tiles, whilst not local to the area, were fashionable in the late 19th and early 20th century

Rooms in Roof Spaces

- Pitched roof dormers are used to increase the height of windows lighting rooms partially in the roof space, and are therefore located on the face of the building; windows that do not break the eaves line do not need a dormer
- Rooflights also provide light and high level ventilation to rooms in roof spaces; they are small, as visually unobtrusive as possible, being low in profile and located on the 'private' side of the roof
- A sense of structural stability is maintained by inserting only small windows in gables

Walls

- Stone or brick walls provide a strong, weather-proof structure; repairs should take the form of repointing, not over-cladding
- Mortar for pointing which is weaker than the stone or brick, and finished flush with its face, does not crack with movement, and allows the walls to breathe
- Poorer quality stone or brickwork was built to be rendered or lime-washed; an appropriate weather-proofing finish would be smooth or roughcast render using local sand and aggregate
- Modern cement-based pebbledash or spardash is inflexible, and can crack, causing dampness
- Stone laid on its natural bed face resists water penetration and frost damage; flat or dressed stone is used for copings and sills to protect the top of walls
- Materials and structural integrity are inter-dependent; applied facings or panels of stone unrelated to structure have no purpose and are visually weak

Windows and Doors

- The style and appearance of windows and doors is governed by their practical performance rather than decorative merit
- Openings are generally small scale, with a greater proportion of wall area to window area
- A visible arch or lintel over an opening demonstrates structural stability
- A projecting sill throws water off the wall
- Windows are set back from the face of the wall to protect the frame – this also avoids a flat and uninteresting façade
- Frames and glazing bars are narrow and chamfered or moulded, to maximise sunlight penetration and reflection
- Both individual panes and windows have vertical emphasis; larger windows are sub-divided into smaller, symmetrical units
- Boarded or panelled doors are human in scale and sturdy in construction

Porches

- Porches are intended to provide weather protection to the doorway, and are therefore small in scale, and simple in form and detail



Sense of place is not safeguarded by the use of false historic styles or standardised components and detailing unspecific to local character or period



The retention of existing features, details etc, or replacement like-for-like is a valuable asset in preserving the character and value of the property



'Modernisation' of an older property using components, detailing and finishes with no local or historic relevance totally alters its character



Effective repairs need to be followed through with suitable detailing – the graceful roof form and good re-slating has been spoilt by chunky hip tiles



Enlarging window openings to allow more light in can have a detrimental visual effect if suitable proportions and styles are not chosen



Where an exact replacement may not be desirable, simply styled windows of similar proportion (height to width and glass to frame) are most appropriate



Hard cement pointing, especially of poor quality (left), and ribbon pointing (right), are visually unattractive and can be damaging to stonework: the mortar will crack away from the stones, allowing rainwater and frost to penetrate the wall; it is also non-permeable, preventing the fabric drying out, encouraging moisture penetration through to the inside



- large chimney with weathering and drip stones*
- good quality local slate roofing with plain clay ridges*
- traditional eaves and verge details - eaves with small or no fascias and clipped verges with no bargeboards*



over-emphasised bargeboards to dormers

bad pointing to stonework using poorly colour-matched mortar

traditional uncoursed or roughly coursed rubble stone wall using local materials



replacement windows with false glazing bars lack modelling and depth – the reflective characteristics of multi-pane glazing are especially lacking

While it is essential for the preservation of the character of traditional buildings to use suitable materials and components for maintenance, the overall effect, and longevity of the repairs, can be seriously compromised by incorrect detailing, techniques inappropriate to the materials used, and poor quality workmanship. Building Regulations approval may be required before repairs are carried out, to ensure compliance with current standards – the Council will be able to advise.

PLANNING

Before undertaking any alterations consult your local Planning Officer, who can offer general guidance on your proposals, and advice on:

- Which alterations require Planning Permission from the Council
- The additional controls exercised in Conservation Areas, and to works affecting Listed Buildings
- Other permissions such as Building Regulations Approval, or specific controls such as Article 4 Directives

Extending or Improving Facilities

- Think carefully about what you are trying to achieve – there may be other ways to provide the additional accommodation you want without building an extension
- It is generally only worthwhile carrying out alterations which will add to the value of the property
- Do not extend beyond the means of your pocket – modest improvements carried out well are better than an over-ambitious scheme that is poor in quality
- Remember that increasing the size of the building reduces the space around it – ensure this will not have a detrimental effect on the property itself or its neighbours
- Work with the character of the original building, not against it – you may have to accept that there are some alterations which would be detrimental to the property
- Unsympathetic alterations, fussy detailing, and ‘modernisation’ by removal of character or features, can all detract from its value
- Properties in a terrace or row of similar buildings should not be altered in any way that destroys the unity of the group
- Modern elements such as patio doors, double garage doors and conservatories (even ‘historic’ styles) are rarely appropriate on an old building, and should never be located on the public or main façade of the property
- Flat roofed extensions and dormers are out of character and dominate the form of a traditional pitched roof building; in any case felted roofs are high maintenance and have a short life span
- Off-the-shelf components do not necessarily offer the best value for money

DESIGN DETAILS

Form and Scale

- Extensions should not dominate the original building – in general they are better smaller in size, with a lower ridge line, and set back slightly from the original
- The form of an extension should be complementary to the original building – similar in proportion, roof pitch and eaves height
- A pitched roof extension can be made to blend into the original seamlessly – flat roofs are not traditional and would only be acceptable in very specific cases
- Porches should reflect the style of the property, and be small in scale

Window and Door Openings

- The proportion of solid wall to openings, and the balance and symmetry of their arrangement, should be similar to the original, not in conflict with it
- Openings which are taller than they are wide are visually more elegant than horizontal ones; where windows are sub-divided into smaller units, these should all be of similar orientation
- Replicate details carefully for replacement doors and windows; poorly designed standard ‘replicas’ and ‘olde worlde’ styles are crude and give mixed historic signals

Detailing

- Keep details simple – repeating an existing feature or decorative style may be appropriate, but avoid overwhelming a small extension with too much detail

Materials

- It is generally preferable to use materials which match those of the original building; where a good match cannot be made, use materials that are sympathetic to the style and feel of the existing
- Avoid using a mix-and-match of too many materials, or false materials such as stone facing
- Good detailing and workmanship are vital to ensure that materials have a long life
- Provided the standard of design and detailing is high, the use of modern materials and components may be justified

alterations which destroy the unity of a terrace or group of similar buildings, such as breaking into the roofline, altering the size or proportion of windows, adding or removing porches or bay windows, removing consistent details or re-facing roofs and walls, are not sympathetic to the character of the group, and should be avoided

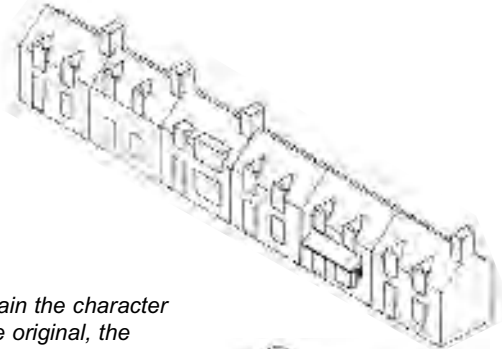

to retain the character of the original, the proportion and form of the extension should be sympathetic to the existing building, as should detailing and materials

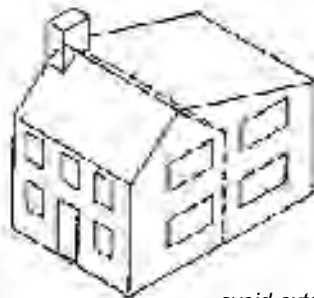
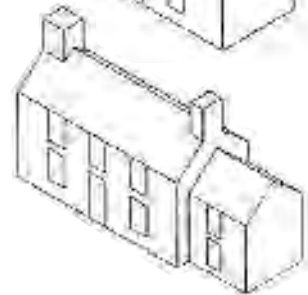
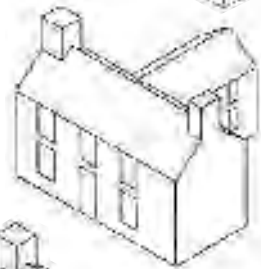

avoid extensions that dominate the existing building, are dissimilar in form, or out of scale with it – this includes flat roofed extensions or dormers, which look top heavy and discordant, and large porches or conservatories

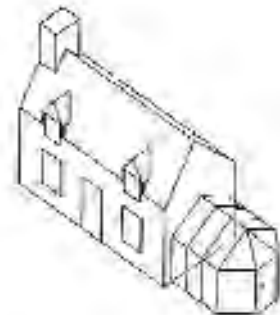

keep the size and proportion of openings, and the area of wall to window, similar to the original, to maintain the appearance of stability and balance



Even alterations that are necessary for practical purposes or have some benefit such as energy reduction, should not be allowed to intrude excessively on to the building or its neighbours



Alterations which match throughout a terrace or group of buildings will retain the unity and character– discuss proposed alterations with neighbours, who may be interested in undertaking similar improvements at the same time



Off-the shelf 'olde worlde' styles are not good replicas, and are often used out of context

CRIME PREVENTION THROUGH DESIGN

Decisions made during the design and planning process by property owners and developers can have a major impact on the prevention of crime and anti-social behaviour, and may be required as a condition of planning approval

Environmental design

- The design and layout of housing and industrial estates, shopping centres, car parks etc, can be used to influence the feeling of security by engendering a sense of communal ownership of the space
- Mixed-use developments without fixed hours of occupation, and estates having a variety of house types, increase the potential for natural surveillance
- Layouts incorporating cul-de-sacs or private drives with a distinct entry point create a defensible space in which strangers are more likely to be noticed
- Unless common areas, paths and playgrounds are overlooked by several adjoining properties, passing pedestrians or vehicles, intruders can feel anonymous, and therefore safe
- Large public or shared-ownership areas may not inspire collective responsibility; areas which clearly belong to someone are less likely to attract loiterers
- Private gardens, rear yards and parking areas should be visible from the property, but be clearly defined by boundaries which deter intruders – thorny hedges, non-climbable fences and lockable gates; long alleys providing access to back gardens are a potential risk
- Planting, walls and other landscape features should not afford shelter for potential criminals: keep ground cover below 1 metre, and raise tree canopies above head height
- Cycle and foot paths need to be reasonably direct, without dead ends or hiding places, and well-lit; reducing the number of paths through the site concentrates pedestrian traffic, and limits potential escape routes
- Shadows and dark areas provide welcome anonymity to criminals – good levels of lighting are crucial to ensure security and safety, and to ensure open spaces will be attractive and well-used

Secure design of buildings

Individual buildings can be protected by various measures, many of which will reduce opportunist crime, and may even discourage determined criminals

- Sturdy and secure doors, windows and gates, incorporating good locks with 'slam-shut' operation
- Security measures such as alarm systems, closed circuit cameras, door viewers and chains
- Lighting covering external doors, side alleys and vulnerable areas
- Security personnel

The following potential weak points need to be considered, and designed out or modified wherever possible:

- Walls, outbuildings, street furniture or planting can be climbed to access windows, roofs or rainwater pipes, or get into gardens
- Flat roofs, porches and balconies, in particular those which connect individual properties, are at first floor level or are hidden from view
- Small panes of glass can be broken to reach thumb latches, window catches or bolts
- Rooflights and access hatches or covers, especially if they have panels that can be removed from the outside
- Patio doors, conservatories, garages and sheds may be more vulnerable, and often have less secure locking devices, than the main building
- Rainwater and other pipes, and also creepers or climbing plants, may be tempting access points
- Poorly-maintained buildings or areas appear to be easy targets for crime, are more likely to encourage vandalism, and may become meeting places where anti-social or criminal behaviour develops

Secured by Design

Secured by Design is a police initiative that seeks to encourage the creation of safe, secure environments by designing out opportunities for, and the risk of, crime. Its principles can be adopted in any development, but housing estates which have been designed and constructed in accordance with the guidance, and have met the approved standards, may be awarded Secured by Design certification.

changes of surface denoting shared private drives will give an added sense that this area is not a public thoroughfare, and that strangers entering may be identified

wheelie bins can be used to gain access over walls and fences – they should be provided with secure storage space

tree canopies should be raised above 2 metres to give clear views beneath; low level planting should be below about 1 metre to prevent it being used as a hiding place

high fences and walls, and bushy or thorny hedges at the rear of gardens discourage intruders; boundaries between properties or which are overlooked may be lower, as unauthorised access is more easily noticed

flat roof, drainpipes, climbing plants and similar tempting means of access should be avoided or be located where they can be seen by passers-by

rear gardens should be secured with gated access points

car parking courts and grouped garages are often located out of the way to reduce noise and disturbance – this can make them hard to supervise and therefore a target for vandalism and crime

good street lighting is needed to all public areas including footpaths, but it should be directed so as not to cause a nuisance to property owners

paths and roads crossing the site need to be direct, easily observed, and well-lit to ensure they feel secure to use; routes which are little-used, poorly lit, have plenty of plant cover, or have many escape routes, can become places where anti-social behaviour develops

well kept neighbourhoods engender pride and a sense of belonging; areas which are not clearly in the ownership of an adjacent property may become neglected

side or rear alleys, especially if they have several access points, are not easily to monitor by natural surveillance

good security measures such as mortice locks, door chains and viewers, alarms etc, give a sense of security as well as deterring opportunists

the elderly or infirm will gain a sense of security if their properties are located where they can be passively monitored by pedestrians

someone entering a cul-de-sac must also leave the same way, doubling the opportunity for being observed

open frontages that are not the responsibility of one adjoining owner, such as with sheltered accommodation, play areas, etc, should be regularly maintained by the Council

clear markings to indicate the point of access into an estate will delineate the private and public spaces, helping to discourage anyone with no business within the estate

A combination of house types will produce a mix of occupiers, increasing the likelihood of people being about during the day, and maximising the opportunities for natural surveillance

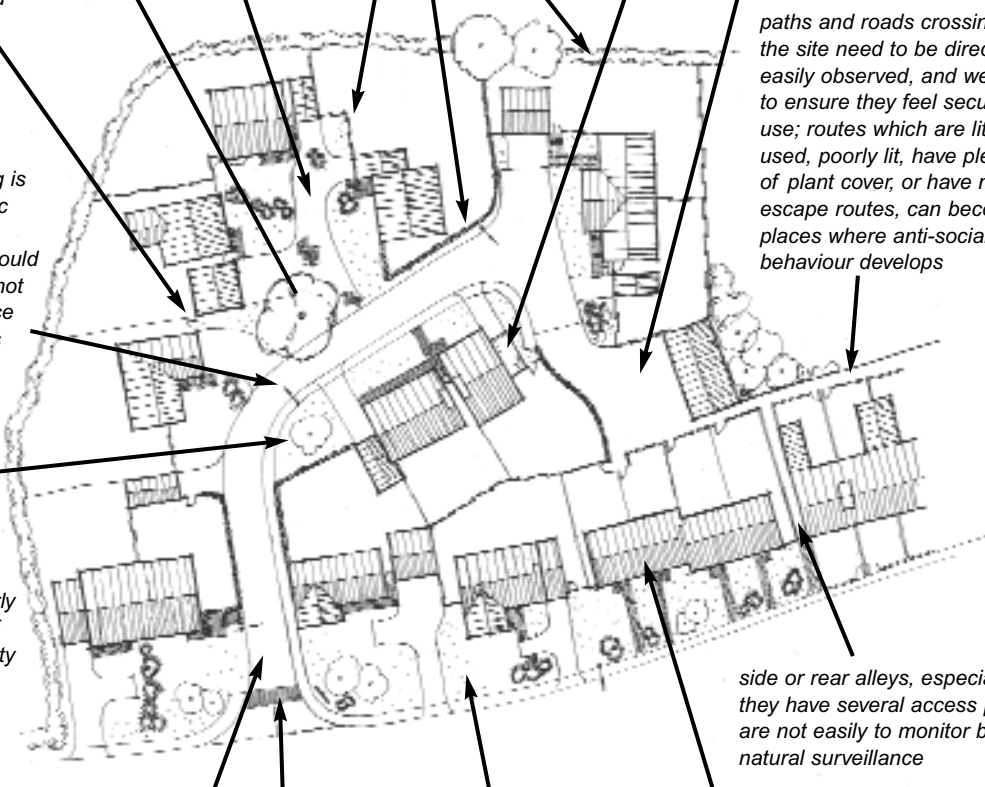

PUBLIC REALM

Public realm describes the amenities available for use at all times by the general public. They may be provided and maintained by public bodies, or form part of a development scheme, to be either maintained under a shared arrangement by all owners or tenants, or adopted by the Local Authority.

OPEN SPACE

Open space exists between all buildings, and is necessary for light, privacy, amenity and safety

- Open spaces need as careful consideration in their design as do the buildings
- A high level of detailing and good quality materials are essential to withstand wear and keep maintenance to a minimum
- Wherever possible, try to ensure that any open areas necessary for amenity, vision at road junctions, or similar, are contained within the ownership of the adjacent property, to encourage regular maintenance
- Spaces should be overlooked – surveillance reduces the risk of vandalism and crime

ROAD DESIGN

Refer to Gwynedd County Council Highways Department for guidance on design of roads. In addition, consider

- Designing out the use of private cars, and designing to reduce the number of journeys taken by them
- Urban scale and detailing will not be appropriate for roads and paths in villages and the countryside – high concrete kerbs and wide pavements are seldom necessary outside of towns
- The impact of roads can be reduced by following the contours of the land, and taking account of natural landscape features
- Whilst safety is paramount, the requirements of all road users should be considered, including cyclists and pedestrians
- Speed reduction techniques need to reflect their location – a simple band of granite setts forming a rumble strip to slow traffic entering a village is usually sufficient
- Large signs are not necessary in town centres or villages where vehicles travel at reduced speed

SURFACES

Road and paving surfaces need to relate to the surrounding context as well as the type of traffic using them

- Choose materials and types of paving to suit the type of traffic and scale of the area – continuous surfaces such as tarmac and large scale paving slabs are appropriate to large heavily-trafficked areas, whereas small scale units such as brick pavers and granite setts are pedestrian-friendly
- Hard impervious surfaces require underground drainage; small element paving is, to some extent, porous
- Materials, colours and surface finishes should be appropriate for the locality – red brick pavers and coloured tarmac are not suited to a town centre of stone and rendered buildings
- Traditional street patterns should be preserved – a pedestrianised street should retain some feature to distinguish the former line of the pavements, for historic continuity and also as an indication of scale
- Different types of paving can be used to separate various uses or routes, or even discourage use, but avoid a proliferation of finishes
- A tactile surface, such as a studded paving slab inset into the pavement, is used to provide a physical indication of danger for the visually impaired, at pedestrian crossings, junctions and the like
- Wheelchair users require fairly smooth surfaces, pavements of adequate width and dropped kerbs
- Surface finishes, as well as layout and road width, can be used effectively to manage traffic and designate priority of pedestrians and vehicles
- By appropriate selection of surface finishes, it may be possible to prohibit or deter parking without the need for yellow lines
- Smaller residential developments may have 'shared use' areas, surfaced to indicate pedestrian priority, where cars must keep to very low speeds
- Softer surfaces such as gravel or bark chippings drain well, making a good finish for informal paths in small developments, parks or in the countryside, where wear will be limited – suitable containment for the gravel or bark, such as stained timber boarding, is required



Lack of structure, and elements that give scale, can make large open spaces characterless, as well as wind-swept; the regularity of the lamp standards only reinforces the lack of interest



Open spaces within a town can be a focus for activity; bus waiting areas, plenty of seating, and the availability of car parking spaces facilitate chance encounters and encourage interaction



Robust detailing and hard-wearing surfaces are required to stand up to the rigours of a well-used public space; the correct choice of finishes will reinforce its character



By contrast, preserving the traditional street pattern and using appropriate materials has enhanced this lane and provided an attractive and practical finish

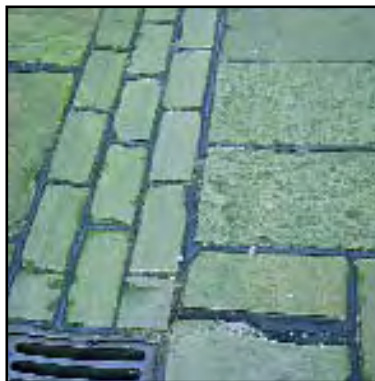

Even if the materials and detailing are good, the overall effect can be spoiled by poor laying techniques or workmanship

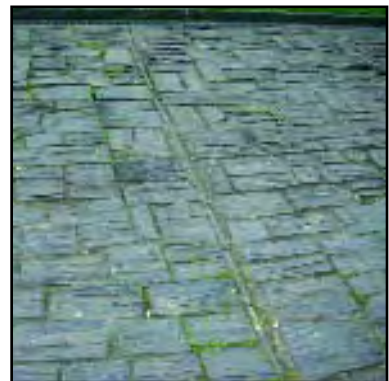

A hard, but well-drained surface, definition of parking bays, and reduction of speed by the generation of 'rumble', have all been cleverly achieved by a good use of local materials



Urban detailing such as standard concrete kerbs should be omitted in favour of a softer margin at verges for country roads



For a rural or semi-rural development, simple natural materials such as slate dust or gravel surfaces, timber edgings, and stone or cobble rumble strips are entirely appropriate



Simple rumble strips at the entrance to villages provide both a visual and aural reminder to reduce speed without being too obtrusive or unsightly

BOUNDARIES

Boundaries form an important element in any landscape, and need to be considered carefully

- Retain and reinforce any existing hedgerows, walls or traditional style fencing
- Consider using any remaining walls from poor-quality existing buildings (which cannot be retained for re-use), or reclaiming the materials, to provide boundaries within a site
- The scale and type of new boundaries should reflect the surroundings, and any particular local detail be replicated, such as slate fencing
- Formal urban settings favour straight brick or stone walls; in rural areas, hedges and fences are more suitable, although the local conditions and materials should always be respected
- Other elements such as gates or cattle grids should be in a similar style to the boundary in which they are located
- Whilst boundaries can be used to provide screening, privacy should be designed into the layout of the development at the initial planning stage
- Outbuildings can perform the function of boundaries effectively, but must be well-maintained – where they have a clear and worthwhile use, such as a garage, they will be more likely to be looked after

SIGNS

Signs are essential to provide guidance, advice and information, but poorly designed or located signs can detract from the landscape, and even be dangerous

- Adopt a standard format for each type of public signage throughout the range, such as the brown signs designated for tourist information, and encourage use of the formats wherever possible for private signs
- Keep the contents of the sign simple – too much information cannot be easily read, especially on roadside signs
- The number and location of signs needs careful consideration, so that they are easily visible, do not cause or create a distraction, nor become an eyesore

FURNITURE

Street furniture refers to items such as signs, bollards, seats, litterbins etc. which are located in public spaces or streets

- The style and materials should be relevant to the overall context of the surroundings, and a 'house style' should be adopted to avoid clutter
- Review requirements and provide only essential items – by reducing signage or locating several signs on one pole, for example
- Negotiate with statutory undertakings to locate services underground or share poles
- Good maintenance of street furniture and planting in public spaces is essential to ensure that the area is welcoming, and to discourage vandalism
- A sufficient level of lighting needs to be provided for safety and security, but it should not cause a nuisance or distraction to others, and its coverage should preferably extend only below the height of the light fitting, to avoid atmospheric pollution

The term 'street furniture' can also refer to other items

- Bus shelters need not be standardised – whilst modern glass canopies may be acceptable in areas without a definitive character, an appropriate individual design may be required in historic areas or villages with a particular character
- Similarly, traditional telephone kiosks and mail boxes may need to be retained or reinstated in historic locations and Conservation Areas
- Public utilities should be encouraged to design compounds or buildings which house equipment, such as electricity sub-stations, in an appropriate style for the locality, rather than utilise a standard design
- Public amenity sites and refuse or recycling skips for public use should be located out of general view and screened, although for security purposes they should be either contained within a compound and manned during specific opening hours, or placed where some other form of surveillance can be maintained, such as a supermarket car park



Existing railings, fences, walls etc. play a very significant part in the streetscape, and should be retained wherever possible



Good use of local materials, good quality detailing and workmanship, ensure that this churchyard wall is appropriate to its location



Non-native species planted as shelterbelts or hedging do not reinforce local character, and may actively discourage indigenous wildlife by reducing the availability of suitable habitats



An over-provision of street furniture results in a cluttered appearance, detracting from the street scene; essential information may also be missed if traffic signs are obscured



Whilst concentrating signs together is neater, providing too much information in a single location can be confusing, especially where traffic may be travelling at speed



Simple signs with a 'house style', easily-read text and standard symbols can be assimilated quickly; the effect is enhanced by the use of appropriate materials



Good street furniture will enhance character - the chunky design of these bollards and railings, the natural stone walling, and the soft surface finish to the path, are a perfect choice for the shoreline



Streetlights should be suited to their location, both in style and also in the quality of light that they provide; this should be adequate for safety and security needs, but should not be obtrusive



Unattractive publicly-owned facilities should be screened, especially if they are poorly maintained; having the potential for some natural surveillance will discourage vandalism

AFFORDABLE HOUSING

Housing available for purchase, rent or part ownership at an affordable price relative to local income, and which will be safeguarded for this purpose in the future

Types of affordable housing

- Housing offered for purchase at an affordable price, relative to local incomes, house prices and interest rates
- Housing offered for rent from a Registered Social Landlord, or from a private developer on terms similar to social housing
- Housing offered for part ownership with Registered Social Landlords (social affordable housing), the Council, or private developers

Providing affordability

- Plot size and density depend on the number of dwellings on each site; plots should not be excessive, otherwise the rise in value over time may make them unaffordable in the future
- The type and size of individual dwellings will be established through the findings of a local housing needs assessment, and should be compact enough to keep construction costs to a minimum, but not so small as to be considered unacceptable for modern living
- Minimum standards will apply to ensure the dwellings are sustainable, practical, adaptable and economic to run and maintain
- The design requirements of affordable housing will be no less stringent than for open market housing, and developments must be in keeping with the local character to protect and enhance the town or village in which they are built
- On any site, the affordable housing should not be distinguishable from open market housing either in terms of its standard of design and construction, nor its location within the development

Affordability will be safeguarded by

- Restricting sale of the property to people with a genuine local need for affordable housing
- Fixing future sale prices at an agreed percentage of the open market value, to maintain the relationship with local incomes
- Withdrawing the occupier's rights to alter or extend without express planning permission

Eligibility

To qualify for affordable housing, applicants must be able to prove a genuine 'need' and fall within the definition of 'local' to the specific community

For further information on assessment of local need refer to the relevant Gwynedd Council Planning Authority's Development Plans, Policies and Supplementary Planning Guidance on Affordable Housing

Allocated and Windfall Sites

The Authority will negotiate with developers to determine the element of affordable housing required on allocated sites or on large windfall sites. The element of affordable housing will be set on the basis of evidence of need and site suitability.

The agreed percentage of affordable housing within any development on allocated sites and large windfall sites will need to be integrated into the general layout. Whether this is formal – with orderly building lines and plot widths, similar to a typical street in a town – or informal – irregular clusters of dwellings – will depend on the locality and character of the surrounding area, but in either case, affordable homes can be incorporated into groups of dwellings without being identifiable by location, size or design.

Rural Exception Sites

Occasionally a genuine local need for affordable housing may be identified within a village which cannot be satisfied on sites elsewhere. In this case, the Planning Authority may agree to the construction of one or more dwelling(s) on a suitable site immediately adjacent to the settlement boundary, provided the special character of the village is not compromised. The following factors will need to be taken into consideration:

- Siting of the housing and density of the layout must relate to the existing settlement pattern as well as landscape features of the site, so that growth of the village is natural and organic
- The height, mass and form of the buildings, should be similar in feel to surrounding buildings to avoid overwhelming them
- Materials and construction details should be appropriate for the locality – good contemporary design incorporating traditional materials in innovative ways should be considered in preference to mock historic styles

Allocated and windfall sites

maintain pedestrian links through the site

retain landscape features – hedges, mature trees, etc – which will provide shelter and screening, and maintain the local character

boundary walls, paving and other public realm elements should reflect the local character

layouts should minimise overlooking, noise or other disturbance, both between dwellings and from roads, adjoining sites and other development

a good social mix produces an active neighbourhood that encourages passive surveillance, personal interaction and a sense of ownership

high densities can be achieved with shared pedestrian / vehicle 'courtyards' with appropriate surfacing to keep speeds very low, providing access to, and supervision of, both private areas and public spaces including communal parking

with 'service' areas such as kitchens and bathrooms to the north, and careful orientation of units, the benefits of solar gain to living rooms can be maximised for energy efficiency

*Allocated or unallocated 'windfall' sites in towns and villages should be developed in line with good practice (refer to other sections of the Design Guide).
Where the provision of affordable housing is negotiated with the Authority, units should be integrated into the development so that they are indistinguishable from the open market housing*

On rural exception sites it is essential to use sympathetic forms, massing and scale, incorporate local materials and detailing, and retain existing landscape features and boundaries, to integrate the new into the fabric of the village. This should not prevent innovation, especially where imaginative design is used to improve the energy efficiency and sustainability of the building

'settlement boundary'

rural exception site

Affordable housing on rural exception sites

Design of affordable housing will be carefully controlled by the Planning Authority when detailed permission for construction is sought, to comply with the following:

- Welsh Assembly Government Planning Policy Wales Technical Advice Note 12:Design (2002)
- Policies contained in the relevant Gwynedd Council Planning Authority Development Plans
- Other relevant sections of this Design Guide

Whether the site is allocated for housing under the relevant Gwynedd Council Planning Authority Development Plans, is an infill site or, exceptionally, is a site immediately adjacent to a village boundary, design of the development should be in accordance with good practice. Designers will need to demonstrate they have taken into consideration:

- The nature, orientation and environs of the site; retention of features such as existing through routes; views in and out; landmarks; important landscape elements e.g. trees and hedgerows (refer to the section on Site Development)
- The character of the surrounding buildings and open spaces, so that the development is sympathetic in scale, form, massing, and formality / informality (refer to the section on Building Design for definitions)
- Use of appropriate local materials and detailing for buildings, boundaries and paving (refer to sections on Development in Towns, Building in the Countryside, and Public Realm)
- Transport, energy efficiency, waste disposal, future maintenance, and flexibility (refer to the section on Sustainable Development)
- Safety and security of occupiers and property, minimisation of noise and nuisance, and the creation of quality neighbourhoods which foster a sense of ownership (refer to the section on Crime Prevention)

Affordable housing should provide

- Economy of construction, using materials and construction techniques equivalent to, or better than, those used for similar local properties for sale on the open market
- An adequate modern standard of living and sufficient space to meet the household's needs rather than aspirations i.e. not so spacious as to make it unaffordable in the future
- Energy efficiency and ease of maintenance

Design Principles

The number, size and type of affordable units to be included in any residential development is to be agreed with the Authority. This may include a mix of house types – terraced, semi-detached, detached or flats – to suit various households, dispersed around the site. Quality and space standards will apply to ensure that dwellings are of an adequate size for, and fulfil the needs of, occupiers (for information on specific development standards refer to Gwynedd Council Planning Authority's Supplementary Planning Guidance: Affordable Housing)

The development should be designed to create

- An efficient layout that relates well to its surroundings, existing transport and pedestrian routes, local centre facilities and services
- A sense of place, created by appropriate built forms and attractive public spaces, in keeping with the local character
- Variety in housing types and densities providing a social mix, to ensure a diverse and sustainable community with low resident turnover
- Affordable units which are integrated into the overall development and indistinguishable from the open market housing
- Adequate external spaces for amenity use and parking, to avoid overlooking, and to prevent noise and disturbance. Private space should be defensible, i.e. clearly visible from the house but enclosed by landscape features or planting; public space should be easily maintained and controllable by passive surveillance from a number of dwellings
- Energy efficient buildings that incorporate eco-friendly materials and construction techniques, economical heating systems, and good thermal insulation, are inexpensive to run and maintain, healthier to live in, and will remain economically viable throughout their lifetime
- Flexible and adaptable accommodation suitable for all, including the elderly, disabled, or families with young children. Some units may be designed with potential for alteration at a later date, to meet the changing needs of the family, although future affordability must be maintained
- High standards of design and workmanship, using good quality local materials, whether in traditional or innovative ways, to create a neighbourhood that preserves and enhances the character of its surroundings



Terraced housing achieves the highest densities, and is appropriate in both town (left) and village settings (right); a less formal feel can be created by stepping units to accommodate changes in level and irregular building lines, or the use of local features, detailing etc

Respect for the form, mass and scale of neighbouring buildings, and use of local materials, will integrate new housing into its setting and enhance existing character

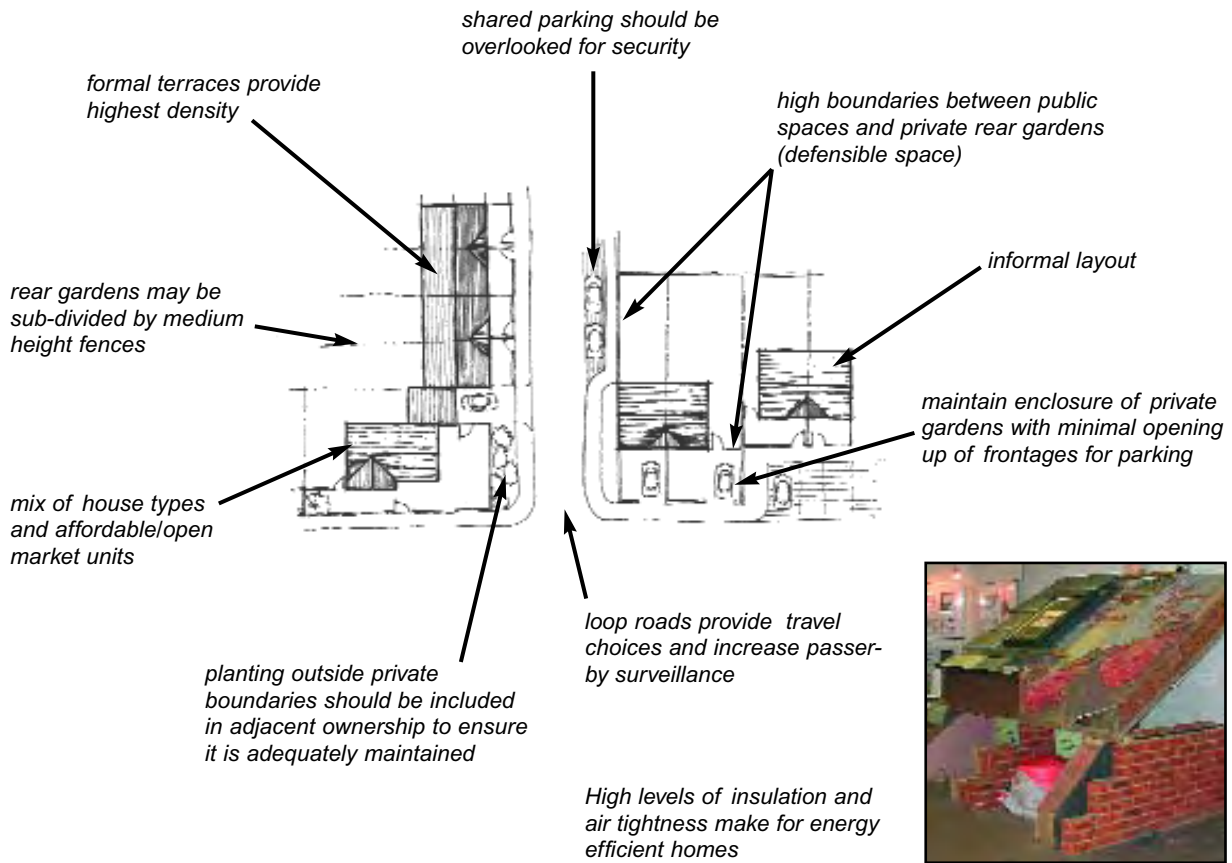

The development pattern of villages has traditionally been fairly informal, and a more relaxed approach to layout design, with emphasis on hard and soft landscape features, will generally be most appropriate for new developments on village infill sites and rural exception sites

Where a genuine local need can be proved, conversion of buildings may be considered

INFORMATION AND REFERENCES

The following reference documents should be consulted for guidance on general matters of planning policy, and specific advice on aspects of design.

Local Policy and Guidance:

Unitary Development Plan	Gwynedd County Council
The Landscape Working for Gwynedd	Gwynedd County Council
Gwynedd Cycling Strategy	Gwynedd County Council

Advice on the Planning System:

Planning Guidance Wales	Welsh Assembly Government
-------------------------	---------------------------

Specific Planning Guidance:

Technical Advice Note 12 (Design)	Welsh Assembly Government
Disability Discrimination Act 1995	United Kingdom Legislation
Planning – A Guide for Householders	Welsh Assembly Government
Planning Permission – A Guide for Business	Welsh Assembly Government
Planning for Sustainable Development: Towards Better Practice	Department of Transport and The Regions
Secured by Design	The Police Authority

Information for Owners of Historic Buildings:

Local Authority Public Information Leaflets

Looking After Your Old Buildings	Cathedral Publications with Gwynedd County Council
Pointing With Lime Mortars	Cathedral Publications with Gwynedd County Council
The Conservation and Renewal of Timber Windows	Cathedral Publications with Gwynedd County Council



GWYNEDD CONTACTS

APPENDIX 2

Artworks Wales

Crichton House
11-12 Mount Stuart Square
Cardiff
CG10 5EE
Tel: 029 20 489543
Fax: 029 20 465458
www.cywaithcymru.org

Cadw

Plas Carew
Unit 5/7
Cefn Coed
Nantgarw Parc
Cardiff
CF15 7QQ
Tel: 01443 336000
Fax: 01443 336001
www.cadw.wales.gov.uk

Civic Trust (Wales)

3 Floor
Empire House
Mount Stuart Square
Cardiff
CF10 5FN
Tel: 02920 484606
Fax: 02920 464239
www.civictrustwales.org

Countryside Council for Wales

North-West Area
Llys y Bont
Parc Menai
Ffordd y Parc
Bangor
Gwynedd
LL57 4BN
Tel: 01248 672500
Fax: 01248679259
www.ccw.gov.uk

Design Commission for Wales

4th Floor Building Two
Caspian Way
Cardiff Bay
CF10 4DQ
Tel: 029 2045 1964
Fax: 029 2045 1958
e-mail: info@dcfw.org
www.dcfw.org

Disability Wales

Wernddu Court
Caerphilly Business park
Van Road
Caerphilly
CF83 3ED
Tel: 02920 853175
Fax: 02920 880702
www.disabilitywales.co.uk

Environment Agency

Ffordd Penlan
Parc Menai
Bangor
Gwynedd
LL57 4BP
Tel: 01248 484067
Fax: 01248 671804
www.environment-agency.gov.uk

Forestry Commission/Enterprise Wales

Victoria House
Rhodfa Fuddug
Aberystwyth
Ceredigion
SY23 2DQ
Tel: 01970 625866
Fax: 01970 626177

Gwynedd Archaeological Trust

Craig Beuno
Garth Road
Bangor
Gwynedd
LL57 2RT
Tel: 01248 352535
Fax: 01248 370925
e-mail: gat@heneb.co.uk

Gwynedd Council

Environment Directorate
Planning & Transportation Service
Planning Unit Arfon Area
Penrallt
Caernarfon
Gwynedd
LL55 1BN
Tel: 01248 682765
Fax: 01286 682771
e-mail: Cynllunio/PlanningArfon.gov.uk
www.gwynedd.gov.uk

Continued over...



GWYNEDD CONTACTS

APPENDIX 2

Gwynedd Council

Environment Directorate
Planning & Transportation Service
Planning Unit Dwyfor Area
Ffordd y Cob
Pwllheli
Gwynedd
LL53 5AA
Tel: 01758 704118
Fax: 01758 704053
e-mail:
Cynllunio/PlanningDwyfor@gwynedd.gov.uk
www.gwynedd.gov.uk

Gwynedd Council

Environment Directorate
Planning & Transportation Service
Planning Unit Meirionnydd Area
Cae Penarlag
Dolgellau
Gwynedd
LL40 2YB
Tel: 01341 424414
Fax: 01341 424440
e-mail:
Cynllunio/PlanningMeirionnydd@gwynedd.gov.uk
www.gwynedd.gov.uk

North Wales Police

Glan-y-Don
Colwyn Bay
Conwy
LL29 8AW
Tel: 0845 6071001 (Welsh line)
Tel: 0845 6071002 (English line)
Tel: 01492 517171
Fax: 01492 512720
www.nwalespa.org

Royal Commission on the Ancient and Historic Monuments of Wales

Plas Crug
Aberystwyth
Ceredigion
SY23 1NJ
Tel: 01970 621333
Fax: 01970 627701
www.rcahmw.org

Royal Society of Architects in Wales

Adeilad Bute
King Edward VII Avenue
Cathays Park
Cardiff
CF10 3NB
Tel: 029 2087 4753
Fax: 029 2087 4926
www.riba.org

Royal Town Planning Institute in Wales

41 Botolph Lane
London
EC3R 8DL
Tel/fax: 29 2036 4479
www.rtpi.co.uk

Snowdonia National Park

National Park Office
Penrhyndeudraeth
Gwynedd
LL48 6LF
Tel: 01766 770274
Fax: 01766 771211
www.snowdonia-npa.gov.uk

Sustrans Cymru

Suite 3
West Bute Street
Cardiff
CF10 5BB
Tel: 029 20 65 0602
Fax: 029 2065 0603
www.sustrans.org.uk

Welsh Development Agency

North Wales
Unit 7
St Asaph Business Park
St Asaph
Denbighshire
LL17 0LJ
Tel: 01745 586293
Fax: 01745 586262
www.wda.co.uk

Welsh Tourist Board

Brunel House
2 Fitzalan Road
Cardiff
CG2 1UY
Tel: 029 2049 9909
Fax: 029 2048 5031
www.visitwales.com



GWYNEDD INTRODUCTION

Background

The landscape strategies for Anglesey and Gwynedd were both published in 1999. The strategies were developed using the Countryside Council for Wales LANDMAP methodology, which establishes a systematic method for recording and retrieving information about landscapes' specific qualities. This information assists decision makers and advisors in development planning, agri-environment, forestry and environmental enhancement. The process is based upon assessing facets or "aspects" of the landscape, some of which are given relative values and others provide supporting information. A more detailed summary of the methodology is given in Appendix A of this report. This document has been developed from the Welsh Development Agency.

The core of the strategy was the subdivision of the two local authority areas into Landscape Character Areas (LCAs). A list and a plan showing their distribution is shown on Figure 1.0. The LCAs provide a meaningful framework of landscape units, of like character, around which policy or management decisions can be made.

Both the Isle of Anglesey County Council and Gwynedd Council consider that, due to the close inter-relationship of each area, particularly in visual and physical terms in the vicinity of the Menai Strait, implementation of any strategy recommendations should be considered in unison.

Purpose

An important landscape strategy conclusion was the need to develop ways and means of ensuring that all parties with an interest in the landscape – council officers, government agencies, landowners, farmers, developers and the public – recognise the need to take into account and understand the differences in landscape character that exist across the two areas. It is from this desire that these design guidelines have been developed. The information is presented primarily in terms of the different LCAs identified, rather than specific sites or areas. Separate guidance notes on agricultural landscapes and transport corridors have been included, as these design issues are common to all areas.

Use

It is hoped that the guidance notes will give users a sense of the varied forms and types of landscape within Anglesey and Gwynedd. The LANDMAP methodology has allowed the identification of the varied elements that make up the landscape. The use of the LCAs as a mechanism to deliver the advice provides a means of examining those elements in relation to specific locations. It has not been the intention of either local authority to prescribe or restrict what could be done or considered in each area. The guidance notes have been prepared to assist all parties to ensure the key issues relating to the landscape are considered when development or landscape proposals are being put forward. The Councils do not wish to hinder innovative design, but they are keen that key local qualities are properly taken into account.

Many of the key issues relate to more than one LCA and it is intended that users should refer to the LCA in which their proposed scheme is located. To assist cross references to adjacent LCAs or broader design guidance elements are provided.



GWYNEDD INTRODUCTION

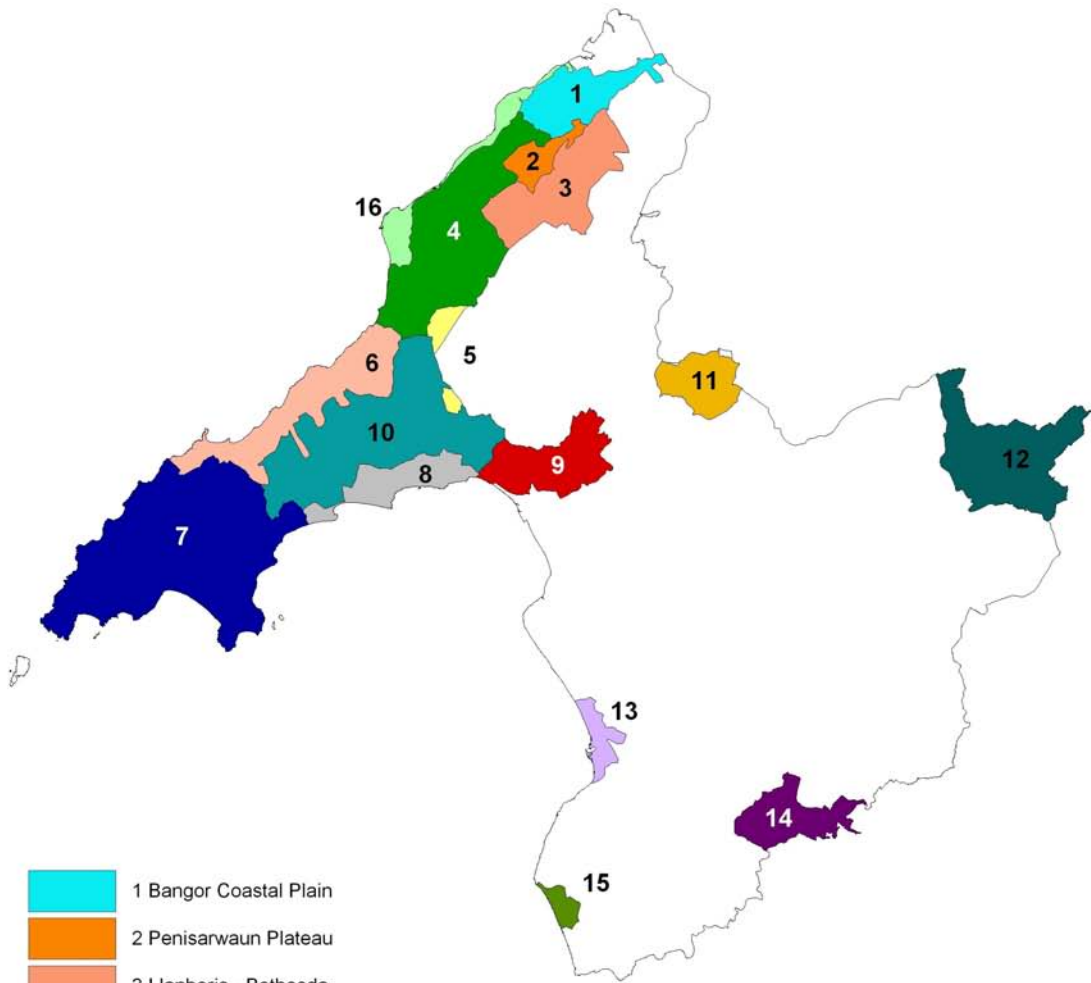

-  1 Bangor Coastal Plain
-  2 Penisarwaun Plateau
-  3 Llanberis - Bethesda
-  4 Caernarfon - Coast and Plateau
-  5 Snowdon Massif
-  6 Llyn North Coast
-  7 Western Llyn
-  8 Pwllheli - Criccieth Coast
-  9 Porthmadog
-  10 Central Llyn
-  11 Blaenau Ffestiniog
-  12 Llandderfel
-  13 Barmouth
-  14 Corris
-  15 Tywyn
-  16 Menai Coast

CHARACTER



- Narrow coastal plain, bounded inland by Snowdon Massif and overlooked from the National Park
- Dissected by a number of small south-north running streams, often small, wooded valleys
- Landscape pattern largely reflects influence of Penrhyn Estate – planned, formal parkland, estate farms and settlements
- Dissected by A55 road, opened up vista of area, important in setting sense of entrance to Gwynedd
- Vernacular boundaries, especially slate fences, cloddiau and hedges

LOCATION

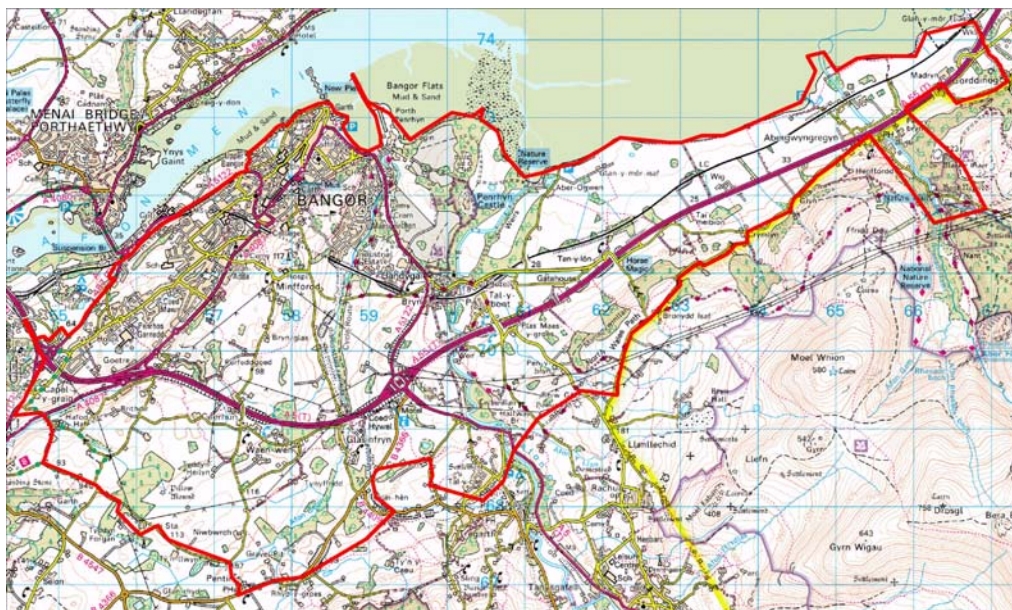

This map is reproduced from Ordnance Survey material with the permission of Ordnance Survey on behalf of The Controller of Her Majesty's Stationary Office. © Crown copyright. Unauthorised reproduction infringes Crown copyright and may lead to prosecution or civil proceedings. Cynor Gwynedd – 100023387 – 2005.

Continued over...



GWYNEDD BANGOR COASTAL PLAIN

LANDSCAPE
CHARACTER
AREA

1

KEY DESIGN ISSUES



TRANSPORT CORRIDORS

New development and management proposals should ensure that:

- Visual impacts from and towards main road/rail corridors are properly considered
- Mitigation measures reflect the wider landscape structure and that sites are not considered in isolation
- The location takes local landforms into account e.g. by retaining existing boundaries/trees and setting buildings along slopes, avoiding breaking ridgelines. Area is adjacent to and overlooked from the National Park
- Since the area is a gateway to Gwynedd, the implications upon perceived quality of the area should be addressed
- A number of key landmark buildings are considered – Penrhyn Castle, the University, and Ysbyty Gwynedd. The impacts upon their settings should be fully considered



HABITAT MANAGEMENT

There are a number of important habitats in this area, including broad-leaved woodland, saltmarsh, mire and grassland. Any development or management scheme should ensure that:

- Direct and consequential impacts upon habitats are properly addressed
- Potential for habitat development or enhancement are considered
- The importance of broad-leaved woodland is recognised
- Any habitat management schemes consider Tir Gofal and the local Biodiversity Action Plan in their recommendations and implementations



HISTORIC LANDSCAPES

Part of the area has been included in the Register of Landscapes of Outstanding Historic Interest in Wales. The area exhibits a mix of historic landscape characters, with the medieval town of Bangor, the 19th century realigned field patterns along the northern coastal strip and the legacy of the Penrhyn Estate predominant. All proposals for development and management should:

- Respect the nature of the pattern and detail of the historic fabric of the landscape
- Ensure that direct and indirect impacts on both upstanding features and buried remains (known and unknown) are taken into account (this could include visual impacts upon the setting of historic landscapes, or disruption to the pattern and scale of these elements).



SETTLEMENT EDGE

Development schemes around settlement edges should:

- Be of a form and scale that reflects the character of each settlement
- Be considered in terms of impacts upon the wider landscape, rather than the site alone
- Seek to utilise landform and vegetation patterns to assist in mitigation of any impacts

It is important that standard solutions are not applied in order that the inherent characteristics of the locality are incorporated into the design.

FUTURE ISSUES

The area is likely to see continued pressure for development seeking to take full advantage of the transportation network. Integration with the wider landscape will be vital. Bangor will also continue to be the focus for residential development. Thorough attention to detail necessary. Effective agricultural land management by Penrhyn Estate and University essential. See Guidance Notes on Transport Corridors and Agricultural Landscapes.

CHARACTER



- Agricultural area with distinct small/regular gently undulating
- Occupying an intermediate zone between coast on or around 100m contour
- Exhibits a number of post glacial landforms such as alluvial fans
- Number of small, densely clustered settlements
- Large areas of woodlands and plantations

LOCATION

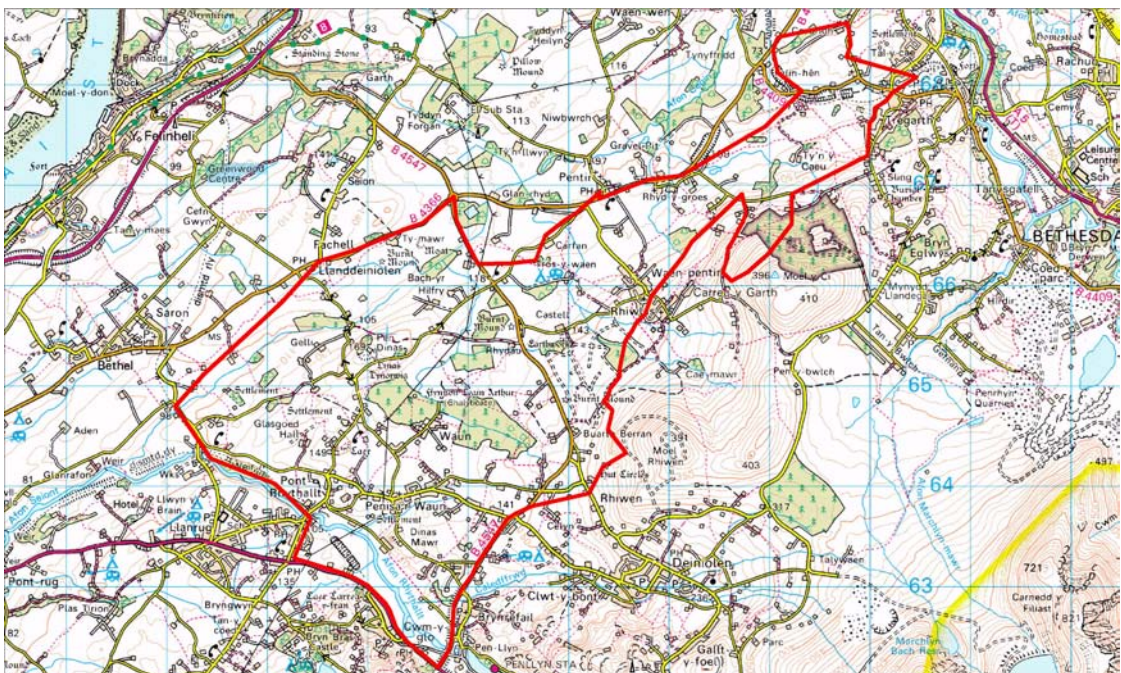

This map is reproduced from Ordnance Survey material with the permission of Ordnance Survey on behalf of The Controller of Her Majesty's Stationary Office. © Crown copyright. Unauthorised reproduction infringes Crown copyright and may lead to prosecution or civil proceedings. Cyngor Gwynedd – 100023387 – 2005.

Continued over...



GWYNEDD PENISARWAUN PLATEAU

LANDSCAPE
CHARACTER
AREA

2

KEY DESIGN ISSUES



BUILDINGS – FORM AND MATERIALS

Any new development proposals should ensure that:

- The location, scale and form of building reflects the settlement pattern. Most settlements are small and often densely clustered
- Materials untypical of the area – pantiles, light bricks are avoided, and traditional patterns e.g. use of local stone, are maintained.



HABITAT MANAGEMENT

There are a number of important habitat types in this area, including marshy grassland, reed beds, mire, saltmarsh and broadleaf woodland. Any development or management scheme should ensure that:

- developments are integrated into the landscape i.e. use of landform, hedges, trees etc., use of vernacular boundaries
- direct and indirect impacts upon habitats are properly addressed
- potential for habitat development or enhancement is considered, to link with Tir Goral and local Biodiversity Action Plan
- The potential to increase diversity of plantations, particularly conifer, over a longer term is examined.



HISTORIC LANDSCAPES

Part of the area has been included in the Register of Landscapes of Outstanding Historic Interest in Wales. The area exhibits a distinct historic landscape character, which is built on elements (some relict, many still in use) which date from the prehistoric period and demonstrate centuries of continuity. All purposes for development and management should:

- respect the nature of the pattern and the detail of the historic fabric of the landscape
- Ensure that direct and indirect impacts on both upstanding features and buried remains (known and unknown) are taken into account (this could include visual impacts upon the setting of historic landscapes, or disruption to the pattern and scale of these elements).

FUTURE ISSUES

The area may suffer from decline in the farming sector or changes in agricultural practices. See Guidance Note on Agricultural Landscapes.

CHARACTER



- Fringe of Snowdon Massif, includes extensive areas of former slate workings
- Typified by small, nucleated quarrying communities
- Water bodies, woodlands and wet marshy areas important features
- Tourism becoming increasingly important

LOCATION

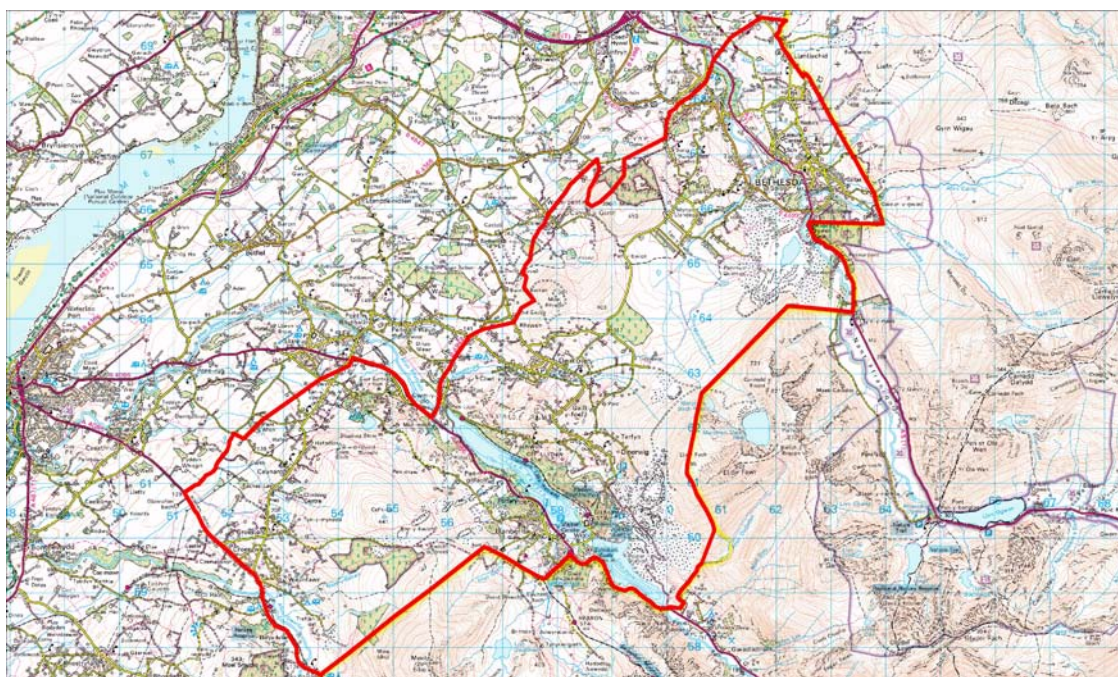

This map is reproduced from Ordnance Survey material with the permission of Ordnance Survey on behalf of The Controller of Her Majesty's Stationary Office. © Crown copyright. Unauthorised reproduction infringes Crown copyright and may lead to prosecution or civil proceedings. Cyngor Gwynedd – 100023387 – 2005.

Continued over...





GWYNEDD LLANBERIS-BETHESDA

LANDSCAPE
CHARACTER
AREA

3

KEY DESIGN ISSUES

	<p>BUILDINGS – FORM AND MATERIALS</p> <p>Any new development proposals should ensure that:</p> <ul style="list-style-type: none"> ▪ The location, scale and form of building reflects the settlement pattern. Most settlements are small and often densely clustered ▪ Materials untypical of the area – pantiles, light bricks, are avoided, and traditional patterns are maintained, e.g. the use of slate as a roofing material. <p>This area abuts and is overlooked by the National Park and forms an important buffer landscape.</p>
	<p>QUARRYING LANDSCAPES</p> <p>Much of the area has been included in the Register of Landscape of Outstanding Historic Interest in Wales. The areas of abandoned slate quarries and waste tips provide perhaps the over-riding historical and cultural landscape identity of Gwynedd, as well as offering potential for a number of opportunities for the future e.g. recreational, habitat management, reclamation, employment.</p> <p>Any proposals should:</p> <ul style="list-style-type: none"> ▪ recognise the historic and cultural significance of these areas ▪ respect the nature of the pattern and the detail of the historic fabric of the landscape ▪ recognise the nature conservation potential of these areas within the overall historical and cultural context ▪ Ensure that direct and indirect impacts on both upstanding features and buried remains (known and unknown) are taken into account (this could include visual impacts upon the setting of historic landscapes, or disruption to the pattern and scale of these elements). ▪ Recognise the scope to use the scale of these sites to accommodate development and provide a particular landscape quality.
	<p>HABITAT MANAGEMENT</p> <p>New development and management proposals should seek to:</p> <ul style="list-style-type: none"> ▪ provide for wider management of key habitats – broadleaf woodlands, heaths, mires, grassland and exposed rock/quarry tips ▪ develop and enhance the existing habitat and link with the local Biodiversity Action Plan ▪ Ensure proper integration into other programmes, such as Tir Gofal.

FUTURE ISSUES

Llanberis, a tourist ‘Honey Pot’, will continue to form a focus for tourist related development. The area forms part of the Slate Area Initiative and could see changes in respect of employment related developments. Careful attention to detail required in order to integrate necessary developments with the landscape. Outlying areas may suffer from decline in the farming sector or changes in agricultural practices. See Guidance Note on Agricultural Landscapes.



GWYNEDD CAERNARFON-COAST AND PLATEAU

LANDSCAPE
CHARACTER
AREA

4

CHARACTER



- A long broad fringe adjacent to the Menai Coast LCA, extending to the upland fringes of Moel Tryfan and Mynydd y Cillgwyn
- Character of landscape influenced by glacial actions and resultant deposits and landforms
- Mixture of settlement types – small villages to large towns. Caernarfon, important historic core, with modern settlement edges of varying quality
- Range of coastal habitats and landscapes, which contribute to character of the area.

LOCATION

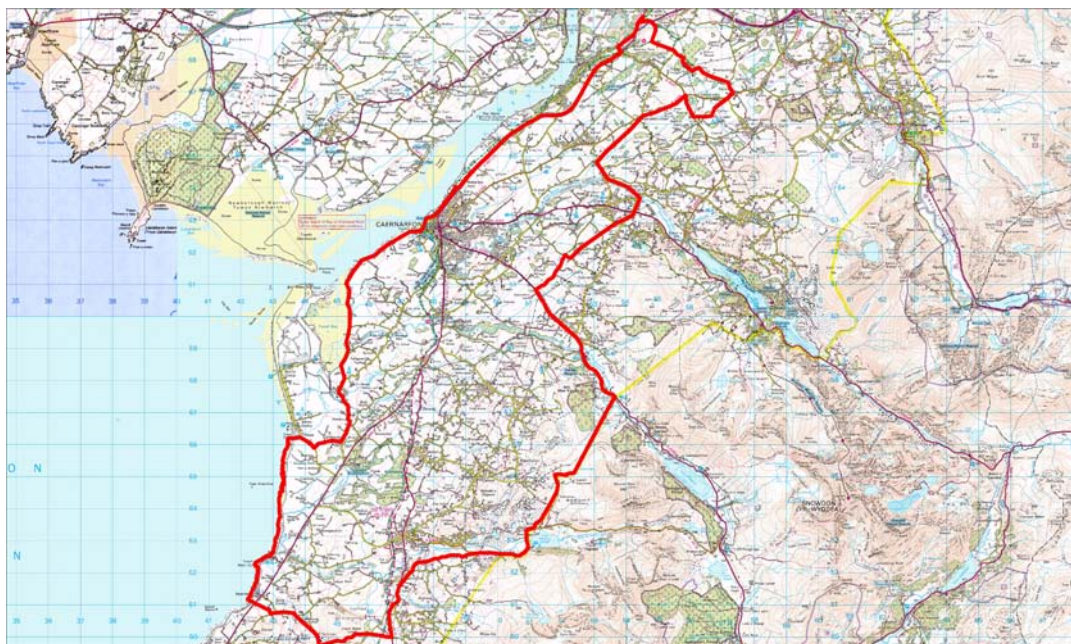

This map is reproduced from Ordnance Survey material with the permission of Ordnance Survey on behalf of The Controller of Her Majesty's Stationary Office. © Crown copyright. Unauthorised reproduction infringes Crown copyright and may lead to prosecution or civil proceedings. Cyngor Gwynedd – 100023387 – 2005.

Continued over...



GWYNEDD

CAERNARFON-COAST AND PLATEAU

LANDSCAPE
CHARACTER
AREA

4

KEY DESIGN ISSUES



SETTLEMENT EDGE

Development around settlement edges should:

- be of a form and scale that reflects the character of each settlement
- be considered in terms of impacts upon the wider landscape, rather than the site alone
- seek to integrate into the landscape using landform, hedges, trees, etc. to minimise impacts

It is important that standard solutions are not applied in order that the inherent characteristics of the locality are incorporated into the design.



HISTORIC LANDSCAPES

Part of the area has been included in the Register of Landscapes of Outstanding Historic Interest in Wales. The area displays a complex mix of historic landscapes of different characters, retaining elements of earlier prehistoric, medieval and post medieval landscapes. All proposals for development and management should:

- respect the nature of the pattern and the detail of the historic fabric of the landscape
- Ensure that direct and indirect impacts on both upstanding features and buried remains (known and unknown) are taken into account (this could include visual impacts upon the setting of historic landscapes, or disruption to the pattern and scale of these elements).



COASTAL LANDSCAPES

Development and management proposals should take into account:

- any direct or indirect impacts upon the range of coastal habitats
- the visual impact on people's perception of the coast, its character and qualities



QUARRYING LANDSCAPES

The areas of abandoned slate quarries and waste tips provide perhaps the over-riding historical and cultural landscape identity of Gwynedd, as well as offering potential for a number of opportunities for the future e.g. recreational, habitat management, reclamation, employment. Any proposals should:

- recognise the historic and cultural significance of these areas
- Consider the visual impacts of any scheme. Many of these sites readily blend into the wider landscape
- recognise the nature conservation potential of these areas within the overall historical and cultural context
- recognise the scope to use these sites to accommodate development and provide a particular landscape quality



HABITAT MANAGEMENT

New development and management proposals should seek to:

- provide for wider management of key habitats – broadleaved woodlands, heathland, mires, coastal edge, reed beds and grassland
- develop and enhance the existing habitat and link with the local Biodiversity Action Plan
- ensure proper integration into other programmes, such as Tir Gofal

FUTURE ISSUES

Continued pressure for tourist related developments. Ongoing and possible road improvements to A487. Penygroes could be the focus for additional employment activity. Caernarfon will continue to be a focus for employment, residential and tourist related development. Management of outlying areas may suffer from decline in farming or changes in agricultural practices. Coastal management may require careful consideration. See [Guidance Notes on Transport Corridors and Agricultural Landscapes](#).

CHARACTER



- Small, fringe area to remainder of Gwynedd formed by those parts of Snowdonia and the National Park
- Upland, mountain character
- Includes former slate workings in Dyffryn Nantlle
- Vernacular boundaries: dry stone walls

LOCATION

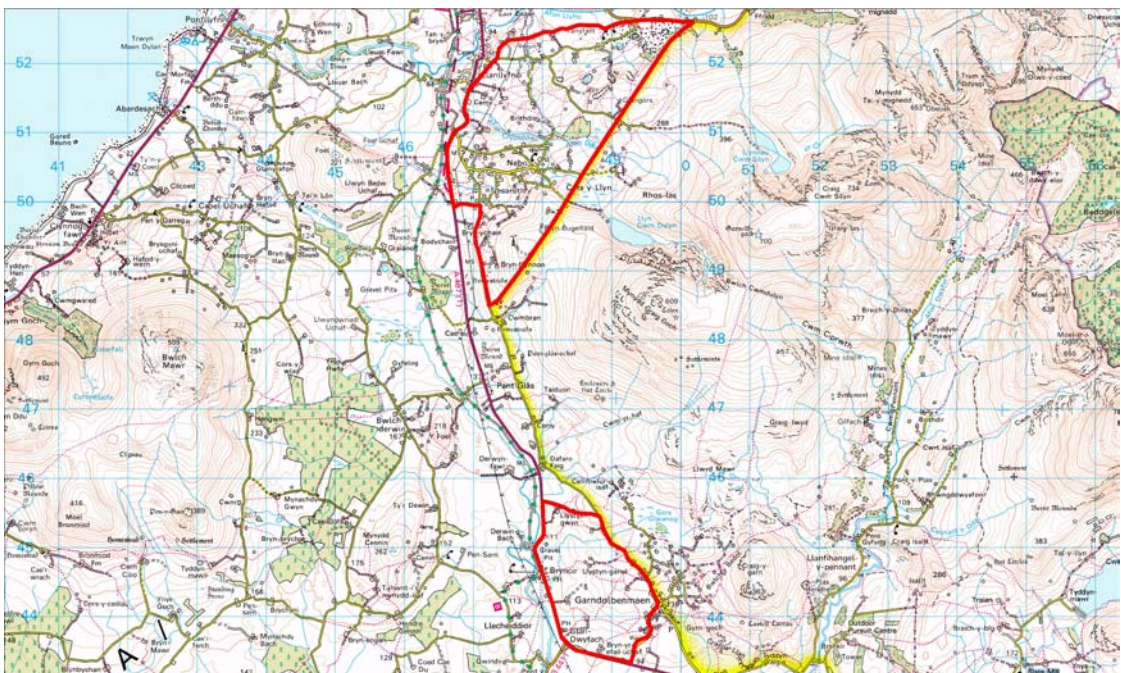

This map is reproduced from Ordnance Survey material with the permission of Ordnance Survey on behalf of The Controller of Her Majesty's Stationary Office. © Crown copyright. Unauthorised reproduction infringes Crown copyright and may lead to prosecution or civil proceedings. Cyngor Gwynedd – 100023387 – 2005.

Continued over...



GWYNEDD SNOWDON MASSIF

LANDSCAPE
CHARACTER
AREA

5

KEY DESIGN ISSUES



HABITAT MANAGEMENT

New development and management proposals should seek to:

- Provide for wider management of key habitats – broadleaved woodlands, heaths, mires, marshy grassland and open water.
- develop and enhance the existing habitat and link with the local Biodiversity Action Plan
- Ensure proper integration into other programmes, such as Tir Gofal.



HISTORIC LANDSCAPES

Part of the area has been included in the Register of Landscapes of Outstanding Historic Interest in Wales. The area displays a strong historic landscape character of small, regular fields and scattered cottage settlement whose origins lie in 19th century enclosure, often associated with the slate quarries. In place, these overlie relict archaeological sites of earlier periods. All proposals for development and management should:

- respect the nature of the pattern and the detail of the historic fabric of the landscape
- Ensure that direct and indirect impacts on both upstanding features and buried remains (known and unknown) are taken into account (could include visual impacts upon the setting of historic landscapes, or disruption to the pattern and scale of these elements).



RELATIONSHIP TO NATIONAL PARK

Any developments or management proposals should recognise possible visual impacts upon the western edge of the Snowdonia National Park. Views into the area from the National Park are critical. This will influence location, scale, form and materials used in any development.



QUARRYING LANDSCAPES

The areas of abandoned slate quarries and waste tips provide perhaps the over-riding historical and cultural landscapes identity of Gwynedd, as well as offering potential for a number of opportunities for the future e.g. recreational, habitat management, reclamation, employment. Any proposals should:

- recognise the historic and cultural significance of these areas
- respect the nature of the pattern and the details of the historic fabric of the landscape
- recognise the nature conservation potential of these areas within the overall historical and cultural context
- Ensure that direct and indirect impacts on both upstanding features and buried remains (known and unknown) are taken into account (this could include visual impacts upon the setting of historic landscapes, or disruption to the pattern and scale of these elements).
- Recognise the scope to use these sites to accommodate development and provide a particular landscape quality.

FUTURE ISSUES

Changes in agricultural practices and decline in agriculture could be a cause for concern. See Guidance Note on Agricultural Landscapes.

CHARACTER



- Narrow coastal strip along northern coast of Llyn Peninsula, includes part of the Heritage Coast
- Typified by a string of upstanding landform. Bwlch Mawr, Gyrn Goch, Gyrn Ddu and Garn Boduan, running down to narrow coastal plain
- Small settlements of significant historic and cultural values
- Range of habitat types of importance, particularly coastal and upland heath and rocky outcrops
- Lies within the Llyn Area of Outstanding Natural Beauty

LOCATION



This map is reproduced from Ordnance Survey material with the permission of Ordnance Survey on behalf of The Controller of Her Majesty's Stationary Office. © Crown copyright. Unauthorised reproduction infringes Crown copyright and may lead to prosecution or civil proceedings. Cyngor Gwynedd – 100023387 – 2005.

Continued over...



GWYNEDD LLYN NORTH COAST

LANDSCAPE
CHARACTER
AREA

6

KEY DESIGN ISSUES



HISTORIC LANDSCAPES

A substantial part of the area has been included in the Register of Landscapes of Outstanding Historic Interest in Wales. The area is very rich in historic landscape terms. It contains complex and extensive evidence for the appearance of the landscape at various times, including the prehistoric (especially in the marginal areas), the medieval (town of Nefyn and strip fields around Morfa) and the industrial (coastal quarries and settlements) periods. All proposals for development and management should:

- respect the nature of the pattern and the detail of the historic fabric of the landscape
- Ensure that direct and indirect impacts on both upstanding features and buried remains (known and unknown) are taken into account (this could include visual impacts upon the setting of historic landscapes, or disruption to the pattern and scale of these elements).



HABITAT MANAGEMENT

New development and management proposals should seek to:

- provide for wider management of key habitats – broadleaved woodlands, upland/coastal heaths, grassland, and scree/rocky outcrops
- develop and enhance the existing habitat and link with the local biodiversity Action Plan
- Ensure proper integration into other programmes, such as Tir Gofal.



COASTAL LANDSCAPES

The majority of the coastline is readily accessible or visible to the public. Development and management proposals should take into account:

- any direct or consequential impacts upon the range of coastal habitats
- the visual impact on people's perception of the coast, its character and qualities



TOURISM DEVELOPMENTS

Any proposals for new or expanded tourism developments should:

- seek to use landform and vegetation pattern to mitigate impacts
- Review the potential for less intrusive and less intensive land use. Impacts may be less if development is less concentrated
- reflect scale, pattern and character of the local road network
- seek to ensure that built environment reflect scale, form, pattern and use local materials of the area
- ensure visual impacts from wider area – paths, bridleways, lanes – are fully taken into account

It should be remembered that this character area lies within the Llyn Area of Outstanding Natural Beauty, a nationally designated landscape.

FUTURE ISSUES

Continued pressure for tourist related developments. Improvements to the A499 Llanaelhaearn – Aberdesach should be carefully managed. Changes in farming practices may affect the management of this area and the decline in the farming sector is a cause for concern. See Guidance Note on Agricultural Landscapes.



GWYNEDD WESTERN LLYN

LANDSCAPE
CHARACTER
AREA

7

CHARACTER



- Western extremity of Gwynedd includes Ynys Enlli, landscape dominated by presence and sense of proximity to the coast, includes part of the Heritage Coast
- Landform would be the effect of glacial actions upon older bedrocks
- Coastline ranges from exposed cliff faces on the northern shore, to the broader, sheltered, shelving bays at Aberdaron and Porth Neigwl
- Diverse range of habitats, many of international and national significance, all giving a rich diversity to the landscape.
- Parts of the area are typified by a dispersed settlement typical of the western fringes of Britain.
- Tourism developments (caravan parks and camp sites) have had a marked effect upon the landscape

LOCATION



This map is reproduced from Ordnance Survey material with the permission of Ordnance Survey on behalf of The Controller of Her Majesty's Stationary Office. © Crown copyright. Unauthorised reproduction infringes Crown copyright and may lead to prosecution or civil proceedings. Cyngor Gwynedd – 100023387 – 2005.

Continued over...



GWYNEDD WESTERN LLYN

LANDSCAPE
CHARACTER
AREA

7

KEY DESIGN ISSUES



TOURIST DEVELOPMENTS

Any proposals for new or expanded tourism developments should:

- seek to use landform and vegetation pattern to mitigate impacts
- review the potential for less intrusive and less intensive land use to reduce the impact of development
- reflect scale, pattern and character of the local road network
- seek to ensure that built elements reflect scale, form, pattern and use local materials of the area
- ensure visual impacts from wider area – paths, bridleways, lanes – are fully taken into account

It should be remembered this character area lies partially within the Llyn Area of Outstanding Natural Beauty, a nationally designated landscape.



HABITAT MANAGEMENT

New development and management proposals should seek to:

- provide for wider management of key habitats – broadleaved woodlands, coastal heath and grassland, wetland/saltmarsh and open water
- develop and enhance the existing habitat and link with the local Biodiversity Action Plan
- Ensure proper integration into other programmes, such as Tir Gofal.



COASTAL LANDSCAPES

The majority of the coastline is readily accessible or visible to the public. Development and management take into account:

- any direct or consequential impacts upon the range of coastal habitats
- The visual impact on people's perception of the coast, its character and qualities.



HISTORIC LANDSCAPES

The whole of this area lies within an area included in the Register of Landscapes of Outstanding Historic Interest in Wales. The national importance of this complex and varied historic and cultural landscape should be taken into account when considering development or management proposals. All proposals for development and management should:

- respect the nature of the pattern and the detail of the historic fabric of the landscape
- respect the cultural significance of the landscape



SETTLEMENT PATTERN/EDGE

In considering proposals for development or landscape management, consideration should be given to:

- ensuring that the settlement pattern of the area is taken into account – avoid concentrations of development in dispersed settlement areas
- seeking to use landform and vegetation patterns to mitigate impacts
- ensuring that the scale, form and materials of buildings reflects local pattern
- The character of the existing vernacular boundaries: cloddiau, sunken lanes and hedgerows with scattered trees.

FUTURE ISSUES

Ongoing and continued pressure for tourist related developments. Changes in farming practices may affect the management of this area and the decline in the farming sector is a cause for concern. Continued pressure for single dwellings/small sites for residential development may cause 'nucleation' of current dispersed villages/hamlets. See Guidance Note on Agricultural Landscapes.

CHARACTER



- Narrow, lower lying coastal plain lying below the 50 metre contour
- Dissected by a number of small river valleys such as the Afon Erch, Afon Dwyfach and Afon Dwyfor
- Area exhibits a variety of habitats from outer tidal areas, dune systems extending inland to more typical agricultural landscapes
- Tourism is an important feature within the landscape ranging from the 19th century development of Pwllheli and Criccieth to the more recent holiday camp at Penychain.

LOCATION



This map is reproduced from Ordnance Survey material with the permission of Ordnance Survey on behalf of The Controller of Her Majesty's Stationary Office. © Crown copyright. Unauthorised reproduction infringes Crown copyright and may lead to prosecution or civil proceedings. Cyngor Gwynedd – 100023387 – 2005.

Continued over...





GWYNEDD PWLLHELI-CRICCIETH COAST

LANDSCAPE
CHARACTER
AREA

8

KEY DESIGN ISSUES

	<p>TOURISM DEVELOPMENTS</p> <p>Any proposals for new or expanded tourism developments should:</p> <ul style="list-style-type: none"> ▪ seek to use landform and vegetation pattern to mitigate impacts ▪ Review potential for less intrusive and less intensive land use. Impacts may be less if development is less concentrated. ▪ reflect scale, pattern and character of the local road network ▪ seek to ensure that built elements reflect scale, form, pattern and use local materials of the area ▪ ensure visual impacts from wider area – paths, bridleways, lanes – are fully taken into account
	<p>SETTLEMENT PATTERN / EDGE</p> <p>Proposals for development or landscape management should consider: the settlement pattern of the area is taken into account – avoid concentrations of settlement areas the use of landform and vegetation patterns to mitigate impacts the scale, form, and materials of buildings and that they reflect the local pattern.</p>
	<p>HABITAT MANAGEMENT</p> <p>New development and management proposals should seek to:</p> <ul style="list-style-type: none"> ▪ provide for wider management of key habitats – broadleaved woodlands, heaths, grassland, open water, saltmarsh, exposed rock and mires ▪ develop and enhance the existing habitat and link with the local Biodiversity Action Plan ▪ Ensure proper integration into other programmes, such as Tir Gofal.
	<p>HISTORIC LANDSCAPES</p> <p>The western part of this area, around Pwhelli, falls within of Outstanding Historic Interest in Wales. The character parkland. All proposals for development and management</p> <ul style="list-style-type: none"> ▪ respect the nature of the pattern and the detail ▪ respect the cultural significance of the landscape ▪ Ensure that direct and indirect impacts on both are taken into account (this could include visual the pattern and scale of these elements).

FUTURE ISSUES

Improvements to A497 Aberech – Llanystumdwy. It is possible that the area will continue to be the focus for tourist related development. Pwllheli in particular will continue to be the focus for further residential/employment/leisure development. Changes in farming practice may affect landscape management and the decline in the farming sector is a cause for concern. See Guidance Note on Agricultural Landscapes.

CHARACTER



- An area bounded by the Snowdonia National Park to the north, east and south
- Significant cultural and historical influences are evident in the landscape
- Tourism is important in the area with a variety of associated facilities
- Wide range of valuable habitats; wetlands, dunes, broadleaf woodlands and rocky slopes
- Quarry works, commercial concerns and the A487(T) all have an impact on the landscape

LOCATION



This map is reproduced from Ordnance Survey material with the permission of Ordnance Survey on behalf of The Controller of Her Majesty's Stationary Office. © Crown copyright. Unauthorised reproduction infringes Crown copyright and may lead to prosecution or civil proceedings. Cyngor Gwynedd – 100023387 – 2005.

Continued over...



GWYNEDD PORTHMADOG

LANDSCAPE
CHARACTER
AREA

9

KEY DESIGN ISSUES



ENCROACHMENT

The Afon Glaslyn provides an important wetland habitat. Its flat, open character offers potential for reclamation and development. A visually prominent area which requires careful consideration to be given to development to protect the environs of the setting.

- Seek to ensure any developments take into account existing developments within the surroundings.
- Ensure visual impacts are minimised by careful consideration of location and views from the wider landscape, including the National Park.
- Address edge details carefully, through choice of boundary types and materials, and landscape treatment to reflect the character of the area. Avoid dense blocks of planting, seek to follow existing pattern of ditches, streams and water bodies.



IMPACT OF TOURISM

By its nature the area is an important tourist destination – Ffestiniog Railway, Portmeirion, Morfa Bychan and Porthmadog itself, with the marina, as well as its juxtaposition to the Snowdonia National Park.

- All new tourist related developments should be considered in terms of their wider visual impacts within the landscape as well as specific local impacts.
- Any developments should take into account habitats of international/national importance, such as the coastal dunes at Morfa Bychan, and proposals should be drawn up so as to minimise impacts and facilitate longer-term management.
- The scale of developments should reflect the existing vegetation pattern of the area. Particular care must be given to choice and use of species. Mitigation may be better served by changes in location and design details, rather than extensive new planting.



SETTLEMENT EDGE DEVELOPMENT

The quality of the landscape character area is markedly affected by the settlements within it. Most have important historic cores, with a range of fine quality buildings. More recent edge developments are changing that character.

- Seek to ensure new edge developments respect the scale and form of the landscape, in terms of building form, size and scale.
- Try to ensure vernacular qualities of the settlements are retained in new developments.
- Consider varying densities of development to reflect local character.
- Carefully consider choice of materials and colours of buildings to fit into the local context.
- Ensure landscape treatment is considered within the context of the wider landscape. The character area has variable densities of trees and woodlands, and specific boundary details.



GATEWAY TO SNOWDONIA

The area directly abuts the Snowdonia National Park and offers spectacular views of the mountain core. For visitors it represents an important gateway into the National Park. In association with other guidance notes:

- Wider land management programmes should ensure distinctive landscape features, such as field boundaries and broadleaved woodlands, are managed with a view to their interrelationship to the National Park.
- See the area as a 'buffer zone' to the National Park, and ensure all development proposals address this relationship.
- Ensure the wider visual impacts from the National Park of development are taken into account in considering their location, form, scale, materials and colour

FUTURE ISSUES

Ongoing and continued pressure for residential/retail development in Porthmadog and in its vicinity. Improvements to the A487 Tremadog – Porthmadog – Penrhydeudraeth. Coastal management issues. See Guidance Notes on Transport Corridors and Agricultural Landscapes.

CHARACTER



- Broadly relates to the central plateau of the Llyn Peninsula over and above the 50 metre contour.
- Generally homogenous area interspersed by prominent hills such as Mynydd Cennin and Y Foel. Landform dominated by the impact of glacial deposits.
- Essentially agricultural in nature, there are large forestry plantations such as Bwlch Derwin.
- Historic elements remain, with prehistoric and medieval features present, although they are often isolated within the larger areas of 19th century enclosures
- Quarrying has and continues to impact upon the landscape. The character area forms an important buffer zone between the Llyn Area of Outstanding Natural Beauty to the west and Snowdonia to the east.

LOCATION



This map is reproduced from Ordnance Survey material with the permission of Ordnance Survey on behalf of The Controller of Her Majesty's Stationary Office. © Crown copyright. Unauthorised reproduction infringes Crown copyright and may lead to prosecution or civil proceedings. Cyngor Gwynedd – 100023387 – 2005.



GWYNEDD CENTRAL LLYN

LANDSCAPE
CHARACTER
AREA

10

KEY DESIGN ISSUES



HISTORIC LANDSCAPES

The western part of the area has been included in the Register of landscapes of Outstanding Historic Interest in Wales. The area is very rich and varied in historic landscape terms, with evidence for millennia of development in the form of field patterns, dispersed settlement, sites of archaeological interest and transport routes. All proposals for development and management should:

- respect the nature of the pattern and the detail of the historic fabric of the landscape
- Ensure that direct and indirect impacts on both upstanding features and buried remains (known and unknown) are taken into account (this could include visual impacts upon the setting of historic landscapes, or disruption to the pattern and scale of these elements).



HISTORIC MANAGEMENT

New development and management proposals should seek to:

- provide for wider management of key habitats – heaths, mires, grassland, exposed rock and open water
- develop and enhance the existing habitat and link with the local Biodiversity Action Plan
- Ensure proper integration into other programmes, such as Tir Gofal.



SETTLEMENT EDGE

Development schemes around settlement edges should:

- be of a form and scale that reflects the character of each settlement
- be considered in terms of impacts upon the wider landscape, rather than the site alone
- seek to utilise landform and vegetation patterns to assist in mitigation of any impacts

It is important that standard solutions are not applied, in order that developments integrate into the vernacular of the area.

FUTURE ISSUES

Changes in farming practices may affect landscape management and the decline in the farming sector is a cause for concern. Expansion of mineral extraction at Graianog. See Guidance Note on Agricultural Landscapes.

CHARACTER



- Discrete landscape unit surrounded by Snowdonia National Park.
- Strong visual links to adjacent mountains of the Snowdon Massif.
- Landscape dominated by the slate waste of former mineral extraction. This is the town in Wales most strongly associated with slate quarrying.
- Town characterised by distinctive pattern of traditional, slate roofed terraced housing developed as a response to the expansion of slate quarrying in the nineteenth century.
- Lower ground characterised by small fields interspersed with broadleaved woodland blocks. Higher slopes partially covered with forestry plantations.

LOCATION

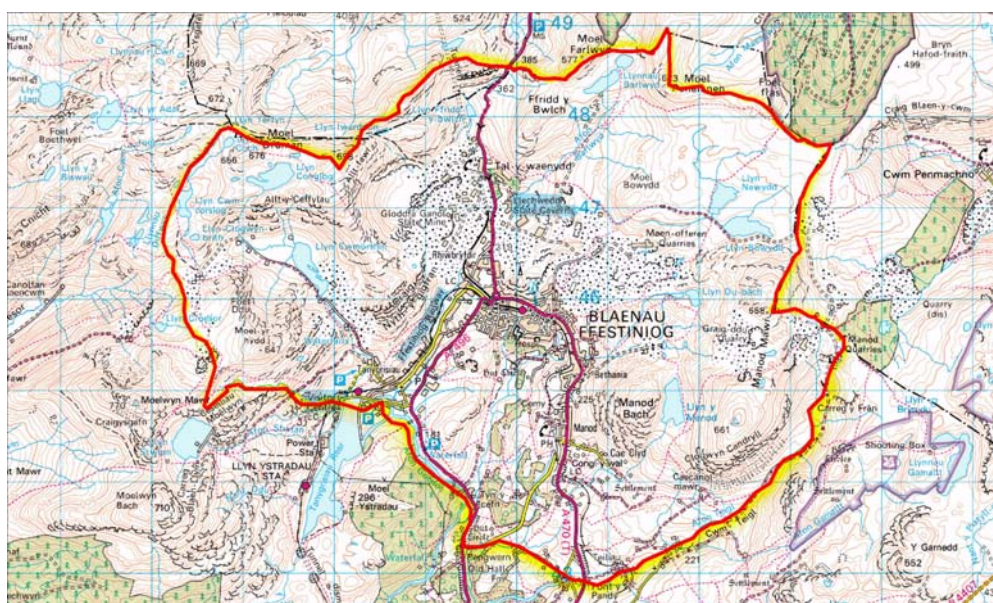

This map is reproduced from Ordnance Survey material with the permission of Ordnance Survey on behalf of The Controller of Her Majesty's Stationary Office. © Crown copyright. Unauthorised reproduction infringes Crown copyright and may lead to prosecution or civil proceedings. Cyngor Gwynedd – 100023387 – 2005.

Continued over...



GWYNEDD BLAENAU FFESTINIOG

LANDSCAPE
CHARACTER
AREA

11

KEY DESIGN ISSUES



SLATE WASTE

The derelict landscape associated the town. Any proposals

- Visual impacts
- Historic and cultural value
- Potentials to develop taken into account.



SETTLEMENT EDGE

The settlement pattern is a distinctive feature of the area, and new development should:

- be of form and scale that reflect the character of the core settlement
- seek to utilise landform and vegetation pattern to assist integration into wider landscape

It is important that standardised solutions are not applied in order that the characteristics of the locality are incorporated into the design.



FORESTRY MANAGEMENT

The eastern edge of the LCA includes part of the Gwydyr Forest. This is a large area of predominantly conifer plantations managed by Forest Enterprise. Although not visibly prominent, they form part of the wider landscape framework. It is important that the visual and biodiversity effects are properly assessed and taken into account in developing and carrying out felling, restocking and other woodland management, e.g. broadleaved species along watercourses and plantation edge, creation of clearance within plantation.



HABITAT MANAGEMENT

The habitat matrix for the LCA is quite diverse, and it presents opportunities for enhancement and development of habitat types to increase habitat diversity through management of the various elements, i.e. upland heath and acid grassland, oak woodland, conifer plantation, disused slate quarry workings. The following should be taken into account:

- Ensure any countryside management schemes retain and enhance habitats.
- Ensure recommendations for habitat development is considered to link with the Gwynedd LBAP.

CHARACTER



- On the eastern edge of the zone from the Arenig Uplands
- Predominantly agricultural, up to 500 metres including Moel y Gydros, Moel Darren, Foel Fach and Moel Emoel.
- Number of broadleaved conifer plantations.
- Varied habitats from open shores of Llyn Tegid.

LOCATION

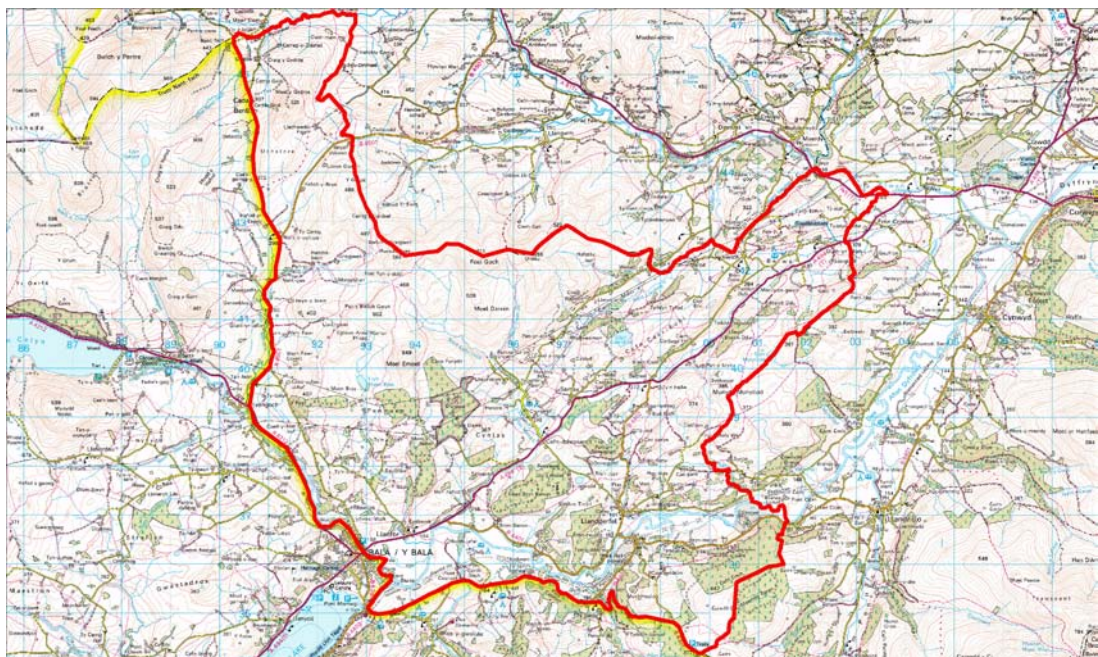

This map is reproduced from Ordnance Survey material with the permission of Ordnance Survey on behalf of The Controller of Her Majesty's Stationary Office. © Crown copyright. Unauthorised reproduction infringes Crown copyright and may lead to prosecution or civil proceedings. Cyngor Gwynedd – 100023387 – 2005.

Continued over...



GWYNEDD LLANDDERFEL

LANDSCAPE
CHARACTER
AREA

12

KEY DESIGN ISSUES



SETTLEMENT EDGE

The river valley floodplain around Bala show signs of increasing development, particularly around the industrial estate. Important that any proposals properly reflect the scale and pattern of the landscape and recognise potential visual impacts upon the north eastern edge of the National Park. Mitigation measures, such as planting and boundary treatment should also reflect this scale and pattern.



FORESTRY

The broadleaved woods and conifer plantations are important visual features within the landscape and provide key habitat elements. Longer term felling proposals should take into account likely visual effects, and the potential for enhanced habitat development.

CHARACTER



- Victorian town of Barmouth and holiday resort of Fairbourne at the mouth of the Mawddach Estuary.
- As a direct consequence of its location to coast flanked by upland landscape it includes elements of LCA 15.
- Marked contrasts within the landscape of broad, open estuary with rising good ground inland formed by the Ardudwy coastal north and the Cadair Idris range to the south.
- Valley sides agricultural in character with areas of woodland and conifer plantation.
- Area typified by expansive vistas and long distance views coastline, dominated by beaches, dune-land, and the local of Barmouth Bridge across the Mawddach Estuary.

LOCATION



This map is reproduced from Ordnance Survey material with the permission of Ordnance Survey on behalf of The Controller of Her Majesty's Stationary Office. © Crown copyright. Unauthorised reproduction infringes Crown copyright and may lead to prosecution or civil proceedings. Cyngor Gwynedd – 100023387 – 2005.

Continued over...



GWYNEDD BARMOUTH

LANDSCAPE
CHARACTER
AREA

13

KEY DESIGN ISSUES

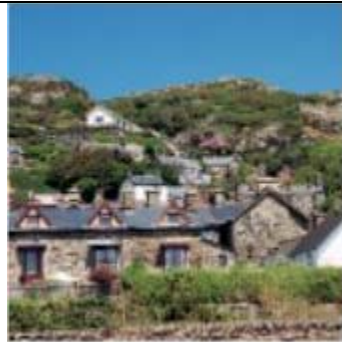

SETTLEMENT EDGE

The two primary settlements of Barmouth and Fairbourne are quite different in scale and form; Barmouth is a linear settlement with attractive Victorian frontage, whereas Fairbourne is a modern, nucleated 'holiday village'. It is important that the following issues are considered:

- Ensure any new developments reflect the different settlement forms.
- When addressing mitigation proposals for settlement edge developments, consider their impacts in broadest sense.



COASTAL LANDSCAPES

Open coastal location, particularly north of Barmouth and around Fairbourne, precludes extensive landscape treatment.



HABITAT MANAGEMENT

The area includes a range of habitat type from coastal to upland fringe. A number of these have statutory protection. Any development or management programme should:-

- Respect protected sites
- Develop opportunities to increase habitat diversity, through management of the key habitats – dunes, inter-tidal sands, wooded Ffridd.
- Ensure distinctive features or elements are retained.
- Ensure recommendations for habitat development and enhancement is considered and link with the Gwynedd LBAP.

CHARACTER



- Includes upper reaches of Dulas and Llefenni valleys that feed into the Dovey and includes open uplands and extensive conifer plantations, together with areas of broadleaved woodland.
- Southern edge National Park, former slate mining valley, with remnant quarry sites and slate waste.
- Visual impact less extensive than for other former slate mining areas.

LOCATION

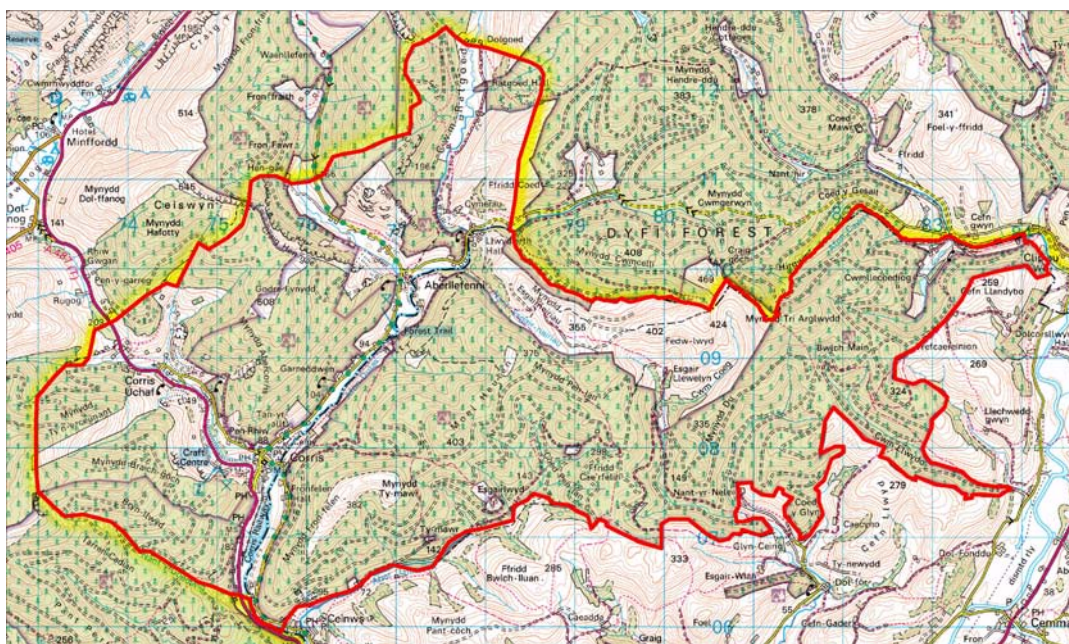

This map is reproduced from Ordnance Survey material with the permission of Ordnance Survey on behalf of The Controller of Her Majesty's Stationary Office. © Crown copyright. Unauthorised reproduction infringes Crown copyright and may lead to prosecution or civil proceedings. Cyngor Gwynedd – 100023387 – 2005.



GWYNEDD CORRIS

LANDSCAPE
CHARACTER
AREA

14

KEY DESIGN ISSUES



FORESTRY MANAGEMENT

The landscape is dominated by conifer plantations and broadleaved woodlands. Felling, restocking and management proposals for areas should ensure visual and habitat issues are properly considered, e.g. broadleaved species along watercourses, creation of clearances.



SLATE WASTE

A number of former slate quarries remain scattered throughout the area. Any development considers the visual, biodiversity and industrial archaeology of each quarry.

CHARACTER



- Ancient settlement associated with St Cadfan, now dominated by tourist developments.
- Flat, open coastal landscape adjacent to mouth of Afon Dysynni with little or no screening vegetation and consequent sharp edges between town and country, and upland fringes inland.
- Important coastal habitats, including dune systems, with statutory designations.

LOCATION



This map is reproduced from Ordnance Survey material with the permission of Ordnance Survey on behalf of The Controller of Her Majesty's Stationary Office. © Crown copyright. Unauthorised reproduction infringes Crown copyright and may lead to prosecution or civil proceedings. Cyngor Gwynedd – 100023387 – 2005.



GWYNEDD TYWYN

LANDSCAPE
CHARACTER
AREA

15

KEY DESIGN ISSUES



SETTLEMENT EDGE

The existing settlement edge is characterised by a sharp edge. Little screening potential, important that future developments seek through design, aspect and location to mitigate visual impacts. This particularly relates to caravan parks and other tourist developments.



HABITAT MANAGEMENT

There are a number of nationally important coastal habitat features within the LCA. Any future management or development schemes must properly take account of likely effects upon their status. Ensure that the recommendations for habitat development and enhancement are linked with the Gwynedd LBAP.

CHARACTER



- Narrow coastal area running from Dinas Dinlle in the west to Bangor.
- Typified by a varied range of landscape types – woodland, educational, historic, nature conservation, commercial airfield.
- Varied landscape pattern reflecting land use.
- Overriding feature is visual and sensory influence of the sea – tides, wind, patterns of movement.
- Range of distinct boundary features.
- Excludes urban area of Caernarfon which is covered by the Conservation Area and World Heritage Site Designation.

LOCATION

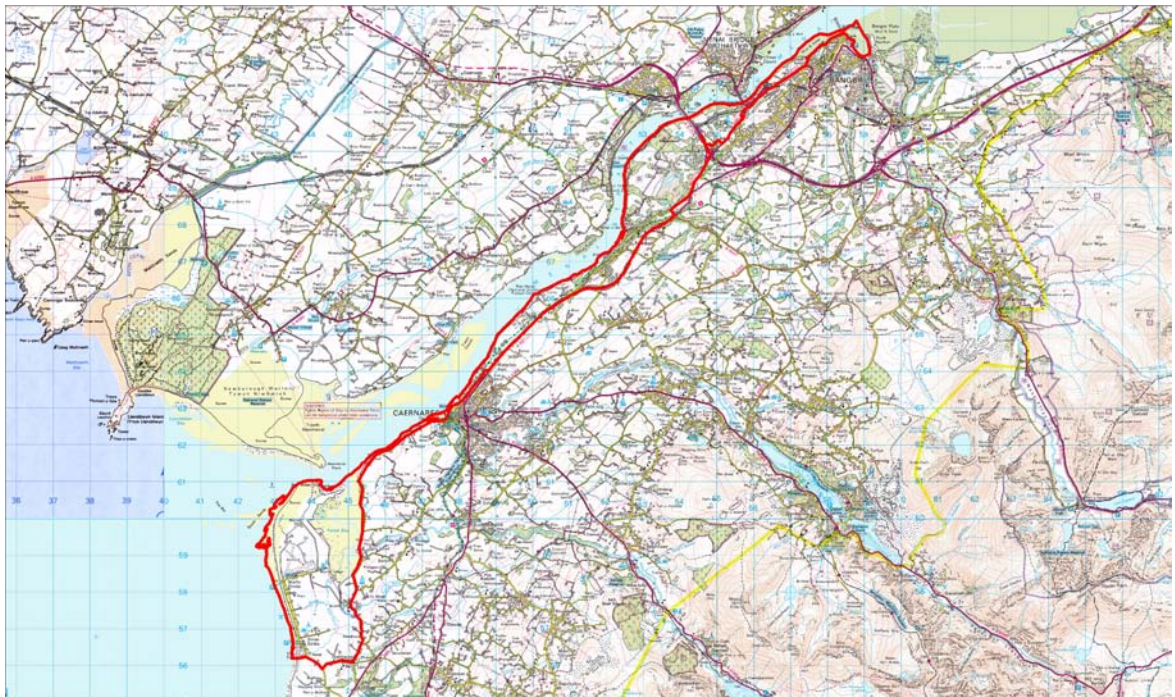

This map is reproduced from Ordnance Survey material with the permission of Ordnance Survey on behalf of The Controller of Her Majesty's Stationary Office. © Crown copyright. Unauthorised reproduction infringes Crown copyright and may lead to prosecution or civil proceedings. Cyngor Gwynedd – 100023387 – 2005.



GWYNEDD MENAI COAST

LANDSCAPE
CHARACTER
AREA

16

KEY DESIGN ISSUES



HABITAT MANAGEMENT

The area contains a number of important habitats relating to the Menai Straits and associated littoral areas, such as Foryd Bay. Any development or management plans should ensure that:

- Direct and consequential effects upon habitats are properly addressed
- Potential for habitat development or enhancement is considered
- Ensure requirements of Gwynedd BAP are addressed



HISTORIC LANDSCAPES

The Vaynol Estate is an important feature of the area, located between Felinheli and Bangor. Included on the Register of Outstanding Landscapes of Historic Interest in Wales. The area is subject to development pressure from the adjacent Parc Menai site but also for events and use of the house and grounds. All proposals for developments should:

- Ensure the underlying historic qualities and features of the parkland are respected
- Ensure that direct and indirect impacts on both upstanding features and buried remains are taken into account
- Ensure that the visual qualities of the area – vistas, viewpoints and setting – are properly considered



RECREATIONAL USES

There are a number of recreational features within the area particularly at Treborrh near Bangor and Bangor Pier. It is important that future proposals at this site and elsewhere within the area properly respect the juxtaposition to the Menai Straits and visual connectivity with Anglesey. Views both in and out need to be carefully considered.



COMMERCIAL USES

There are a number of commercial land uses within the area, such as the industrial area at Griffiths Crossing and adjacent former Ferodo Factory, together with Caernarfon Airport. Future uses of these areas should:

- Ensure views into and out of the site do not detract from the qualities of the area
- Consider impacts upon adjacent land use
- Ensure built form does not detract from the qualities of the area



SETTLEMENT EDGE

The area includes the coastal fringe of Caernarfon and Bangor and includes the settlements of Dinas Dinlle and Felinheli. Development and management schemes should:

- Be of a form and scale that reflects the characters of each settlement
- Be considered in terms of wider landscape effects
- Seek to utilise landform and vegetation to assist in the mitigation of any impacts
- Use local boundary features – cloddiau, hedgerows, walls
- It is important that standard solutions are not applied so as to ensure the inherent local character is incorporated into the design.



EDUCATIONAL LAND USES

The area from Pont Britannia to Bangor is characterised by a high proportion of sites owned by the University, such as the Coleg Normal Campus. The general principles outlined previously apply to this area, particularly wider visual effects and setting.

FUTURE ISSUES

The proximity of Bangor and Caernarfon will ensure that part of the area remains subject to development pressure. Careful consideration will need to be given to detail, but also to broader massing, such as the University area in Bangor. The Menai Straits is an internationally important biodiversity area and impacts, direct and indirect, will increasingly require careful review and consideration.



GWYNEDD TRANSPORT CORRIDORS

Anglesey and Gwynedd are crossed by a number of primary transport routes in the region.

A5/A55(T) - Anglesey and Gwynedd

A487(T) - Gwynedd

A497 - Gwynedd

A499 - Gwynedd

A5025 - Anglesey

A4080 - Anglesey

The Chester – Holyhead railway line runs through Bangor on its way to Holyhead. These roads and the railway line have an important influence upon the perception of both Anglesey and Gwynedd by locals and visitors. This perception is influenced by the speed at which people travel. The faster the speed, the greater the importance of the scale of the adjacent landscape. In developing appropriate design guidance the following factors are considered important.



Continued over...



GWYNEDD TRANSPORT CORRIDORS

Landscape Structure

Much of the landscape associated with roads and railways is already managed and maintained. This is particularly so of the trunk road network. In addressing this within terms of the wider landscape, attention should be given to:-

- Ensuring that the wider landscape corridor associated with transport routes is taken into account. This includes both views into the corridor.
- seeking to enhance biodiversity value of habitats, e.g. by management methods that encourage a variety of plant and animal species
- Ensuring that proposals link in with adjacent habitats and landscape features, e.g. by ensuring that designs integrate with the existing landscape elements.
- Ensuring health and safety issues are taken into account
- ensuring that the setting of historical features/buildings is protected
- Providing all year interest for the road user – this can be achieved through a mixture of herb layer, shrub and tree planning and appropriate management of existing vegetation.

Vistas and Viewpoints

Any proposals for development adjacent to or within the visual zone of a transport corridor should be examined in terms of their impact upon key vistas and viewpoints. Examples include:-

- approach to Bangor from the east and the visual setting of Penrhyn Castle and estate
- Menai Strait – views out from both road bridges
- Malltraeth Marsh on the A5/A55 corridor, Anglesey
- A5/A55 approaches to Holyhead across the Inland Sea and across to Beddmenarch Bay
- A487 from Caernarfon to Y Felinheli – borrowed views across the Menai Strait to Anglesey
- A487 between Nebo and Bryncir – views across to the upstanding peaks of the Llyn Peninsula
- A487 Penmorfa – Tremadog – views across the Glaslyn into Snowdonia
- A499 – Llyn North Coast – views of upstanding peaks along the Llyn coast
- A497 – Aberech – Criccieth – extensive views across coastal fringes and Tremadog Bay in addition careful consideration needs to be given to location of signage and lighting schemes. This is particularly important where darkness is impinged upon by potential light pollution.

Landscape Scale

An important feature of the transport corridors within the area is their often close interrelationship with the scale and pattern of the landscape through which they pass. Notwithstanding the needs for highway safety, developments adjacent to road corridors and improvements to the roads themselves should:-

- take into account the scale and pattern of the landscape
- avoid the introduction of urban elements, such as kerbs and lights, into essentially rural landscapes
- pay careful attention to boundary details, their scale and location
- ensure that development proposals are seen within the context of the wider landscape, as well as the local landscape
- Consider that all roads, railways etc. are, to a greater or lesser extent, elements of the historic landscape which should be considered when works are being planned.

It is important to remember that a number of these roads pass through or are adjacent to nationally designated landscapes, for example Snowdonia National Park, the Anglesey Area of Outstanding Natural Beauty and the Llyn Area of Outstanding Natural Beauty.



GWYNEDD AGRICULTURAL LANDSCAPES

The majority of the landscape of both Anglesey and Gwynedd is agricultural in character and type. Planning should take into account the necessity for development to retain youth and support a balanced community in often rural areas. Both areas are typified by extensive areas of improved grasslands interspersed with a range of other habitats – water bodies, mire, heath, scrub and woodland. Both areas are examined within this design guidance note, with a number of generic factors being considered. It is important that reference is also made to the guidance sheets for each character area. Thus in considering development or land management proposals, the following factors need to be taken into account:-

- Boundaries – field boundaries vary in style and form throughout Anglesey and Gwynedd and are characteristic not only of local area, but of period as well. Examples include



Stone walls



Clawdd



Slate fences



Hedgerows



Post and wire fences



Wet fences (ditches)



Gates/stiles

Each contributes to the particular character of the area. In general every effort should be made to retain and manage boundaries as appropriate to the locality, avoid use of inappropriate materials. If landholdings are rationalised, try to ensure as many of the existing boundaries are retained as possible. New boundaries (e.g. roadside walls) should be in the local style.

- Habitats – agricultural landscapes offer the potential to maintain and increase the variety and quality of rural habitats. Key potential areas include:



Adjacent to and within field boundaries



Poorly drained areas



Streams and ditches



Areas of scrub and woodland



Field heathlands



Arable field margins

In addition, consideration should be given to taking opportunities to increase interest or diversity of existing grassland area through changes to management practices. Schemes should be considered within the context of their wider implications for the area and should be compatible with good agricultural practice.

Continued over...



GWYNEDD AGRICULTURAL LANDSCAPES

Buildings – the development of buildings within the wider countryside raises a number of issues. Whilst the viability of a farm unit should not be compromised, modern farm buildings are often out of scale with traditional farm buildings within the area, which themselves vary in character/appearance according to age, function, area, etc. Careful consideration should be given to :-



Building location in respect of vistas and viewpoints



Colour and scale



Materials



Style



Mitigation

Mitigation requires careful consideration in that much of the area is not typified by extensive tree belts or woodlands. Accordingly the other factors identified become increasingly important. Cadw: Welsh Historic Monuments, ICOMOS (UK) and Countryside Council for Wales have drawn up a non-statutory Register of Landscapes of Outstanding Historic Interest in Wales, in order to raise awareness of the historical dimension alongside the more traditional and long-established concerns of wildlife protection and scenic amenity. The register contains some thirty-six landscape areas, many of which are concentrated in the north west of the country.



GWYNEDD FURTHER INFORMATION

The following organisations will be able to provide advice and guidance on the use of these guidelines, together with an indication of sources of funding.

Gwynedd Council Planning
Transportation Services Council
Offices
Caernarfon
Gwynedd
LL55 1SH
Tel: 01286 672255
Fax: 01286 673324

Forestry Commission
North Wales Conservancy
Clwydd Newydd
Ruthin
Denbighshire
LL15 2NL
Tel: 01824 750492
Fax: 01824 750483

Isle of Anglesey County Council Planning and
Economic Development Department Council
Offices
Llangefni
Anglesey
LL77 7TW
Tel: 01248 752400
Fax: 01248 725412

Coed Cyrmu c/o
Project Officer
Isle of Anglesey County Council/
Gwynedd County Council

Countryside Council for Wales
North West Wales Area Llys Y
Bont
Ffordd Y Parc
Parc Menai
Bangor
Gwynedd
LL57 4BH
Tel: 01248 672500
Fax: 01248 679259

Tir Gofal c/o
Project Officer
Countryside Council for Wales
Welsh Development Agency
North Wales Division
Unit 7
St Asaph Business Park
St Asaph
Denbighshire
LL17 0LJ
Tel: 01745 586293
Fax: 01745 586262

Environment Agency
Ffordd Penlan Parc
Menai
Bangor
Gwynedd
LL57 4BP
Tel: 01248 670770
Fax: 01248 670561

REFERENCES: Countryside Strategies and local Biodiversity Action Plans are being developed by Gwynedd Council and Anglesey County Council, and will be available at County Offices. Tir Gofal officers for both Anglesey and Gwynedd, any proposals should complement objectives of this scheme, available at County Offices and main libraries. Unitary Development Plans, Structure and Local Plans for Gwynedd Council and Anglesey County Council, available at County Offices. Design Manual for Roads and Bridges, Volume 10, in particular supplementary guidance for Wales in "Roads in Lowland Areas", available at County Offices.



GWYNEDD APPENDIX A

LANDMAP Assessment – Approach and Methodology

The CCW/Wales Landscape Partnership Group landscape assessment process *LANDMAP (*landscape assessment and decision making process) has been subject to a series of pilot studies and detailed assessments of a limited number of local authority areas throughout Wales and the methodology details are currently being finalised by CCW.

The basis of the LANDMAP methodology is to provide a means of assessing landscapes for every major type of decision making – agri-environmental, countryside management, development, enhancement and forestry.

The process seeks to optimise the resources available by bringing together the many facets of the landscape into a single, multi-purpose assessment. It adopts an approach that allows the data accrued to be enhanced and developed as opportunities allow.

The process effectively subdivides the landscape into a series of components or 'aspects'. At the time of the survey and analysis, the following aspects were examined in detail:-

- Visual and Sensory
- Biodiversity (vegetation and habitats)
- Earth Science (geology, geomorphology and hydrology)
- History
- Culture – including artistic associations and folklore. These are supported by other contextual data, where no formal assessment was undertaken, but information was gathered which has supported the strategy development process. This has included:-
 - Settlement and Land Use
 - Agriculture
 - Forestry
 - Public Perception
 - Planning and Development Framework
 - Related strategies and initiatives in each instance, where possible, national data sets are utilised so as to ensure compatibility between different areas undertaking LANDMAP and thus providing:-
 - A common framework for landscape data (ecological, historic and cultural) on a national level.
 - Aggregation and dis-aggregation of data between national, Unitary Authority/National Park and local level.
 - A means of detecting and monitoring landscape change.

There are a number of key stages within the LANDMAP process that are relevant to this study. These can be summarised as follows:-

Continued over...



GWYNEDD

APPENDIX A

Stage 1 : Orientation

This initial stage is concerned with establishing the scope of the assessment, the use of the information derived, timescale and programming, resources and the use of a Geographic Information System (GIS) to record data, together with establishing the Local Steering Group, which oversees the management and direction of the study. The members of drawn from local authority, government, and land management organisations.

Stage 2 : Generation of Aspect Areas

This stage is key to the overall development of a landscape assessment and associated strategies. The information for each aspect is held in the form of maps and related data tables, and the aspects themselves are divided into two types.

- (i) Contextual Information – these are descriptive layers of information, but do not necessarily belong to a single discipline. Accordingly it is not possible to evaluate the intrinsic value of the elements within this layer since there is no sound justification for valuing one element against another.

The areas covered within this category area:

- (a) Development
- (b) Settlement Pattern
- (c) Agriculture
- (d) Forestry

- (ii) Evaluated Aspects – these reflect that the LANDMAP process is based upon the fact that most elements within the landscape can be seen to have an intrinsic value within their own aspect and that within these, it is possible to evaluate the relative intrinsic value of the different elements. The aspect areas within this category are:-

- (a) Visual and Sensory
- (b) Biodiversity (vegetation and habitat)
- (c) Earth Science (geology, geomorphology and hydrology)
- (d) History
- (e) Culture including artistic associations and folklore To assist in managing the data and transcribing it into the GIS format, the information gathered in this assessment process is recorded on a standard proforma.

For each aspect, the study is subdivided into a number of discrete, geographical units or 'Aspect Areas' and data is collected on the following:

- Area Description
- Evaluation
- Management Recommendations
- Existing Condition
- Preferred State
- Broad Management Aims
- Urgency of Management Inputs

Continued over...



GWYNEDD APPENDIX A

Within this, the evaluation process adopts a standardised approach which allows for comparison between different local authority areas. In more detail these evaluation categories are as follows:-

Outstanding	-	areas or sites of international or national importance
High	-	areas or sites of regional/county importance
Moderate	-	areas or sites of local importance
Low	-	areas or sites of low value
Unknown	-	where insufficient information exists to allow the element to be properly evaluated

Another important input to this stage of the process is ensuring that the views of the public are incorporated within the overall process in terms of:

- features/landscape which are of value to the local community
 - The sense of local identity within the landscape
 - The value placed by the public on landscapes and individual features
 - What the public considers as being important to conserve, enhance and change
 - The difference between the views of local residents and visitors
- Within the Anglesey study, the public perception element of the landscape assessment has been undertaken by Market Research Wales Limited. The study consisted of a combination of qualitative (focus groups) and quantitative (household questionnaires) techniques. A key feature of this exercise has been the identification of specific data that can be digitised within the GIS format, and provide another layer of information to assist the users.

Stage 3: Landscape Assessment and Recommendations

Stage 3 of the study is concerned with establishing the landscape character for the study area, together with providing management guidance for the various decision makers. The key to this task is the analysis and assessment of the evaluated aspects to provide *Landscape Character Areas* (LCAs). The use of the GIS approach is important in this respect as it allows ease of handling of the different layers of information.

In essence the LCAs provide a series of geographical units of like character and concerns, and the boundaries reflect the inherent form of the landscape. Within the study area it is apparent that the earth sciences data has a primary influence upon the landscape, and in developing the LCAs, this aspect area provided the initial framework against which other aspect areas are appraised. The final definition of the LCA is undertaken by using a matrix approach, where evaluated aspect topics are considered against the evaluation level.

Where difficulty arises in determining the true extent of a Landscape Character Area it is important to establish what underlying qualities are determining the character of the landscape. This will require a thorough review of the evaluated aspect data beginning with visual and sensory qualities and considering the other aspects in turn. For each Landscape Character Area a series of management recommendations will be provided which are based upon the detailed appraisal exercise and reflect relevant policy initiatives of the Local Authority, CCW, WDA and other organisations.